



January 11, 2022

**Carmel Area Wastewater District**

**Final Preliminary Engineering  
Report – Pescadero Road  
Sewer Main Replacement**

**PREPARED FOR:**

Rachél Lather, PE

**PREPARED BY:**

Nicholas Panofsky, PE

**MNS ENGINEERS, INC.**

811 El Capitan Way, Suite 130  
San Luis Obispo, CA 93401  
805.692.6921 Office

[www.mnsengineers.com](http://www.mnsengineers.com)



# Carmel Area Wastewater District



## Final Preliminary Engineering Report – Pescadero Road Sewer Main Extension

---

January 11, 2022

Prepared by:



Nick Panofsky, PE C75008

---

MNS Engineers, Inc.





# Table of Contents

- SECTION 1. PROJECT OVERVIEW ..... 3**
  - 1.1. OBJECTIVE..... 3
  - 1.2. SETTING ..... 3
  - 1.3. EXISTING COLLECTION SYSTEM AND PROPERTIES SERVED ..... 3
  - 1.4. PROJECT GOAL ..... 3
  - 1.5. ALTERNATIVES ..... 5
- SECTION 2. PRELIMINARY ENGINEERING ..... 6**
  - 2.1. DESIGN CRITERIA ..... 6
  - 2.2. EXISTING AND FUTURE FLOWS ..... 6
  - 2.3. PIPE SIZING ..... 6
  - 2.4. ALTERNATIVE A CONCEPTUAL DESIGN ..... 7
    - 2.4.1. ALTERNATIVE A DESCRIPTION ..... 7
    - 2.4.2. HYDRAULIC ANALYSIS ..... 7
    - 2.4.3. REAL PROPERTY ISSUES ..... 9
    - 2.4.4. GEOTECHNICAL ENGINEERING ..... 9
    - 2.4.5. ACCESS ISSUES..... 10
    - 2.4.6. TRAFFIC CONTROL..... 10
    - 2.4.7. BYPASS PUMPING REQUIREMENTS ..... 10
    - 2.4.8. PERMITTING REQUIREMENTS ..... 10
    - 2.4.9. CONSTRUCTION COSTS..... 10
  - 2.5. ALTERNATIVE B CONCEPTUAL DESIGN ..... 11
    - 2.5.1. ALTERNATIVE B DESCRIPTION ..... 11
    - 2.5.2. TRENCHLESS SEWER INSTALLATION ..... 13
    - 2.5.3. HYDRAULIC MODEL ..... 13
    - 2.5.4. REAL PROPERTY ISSUES ..... 13
    - 2.5.5. ACCESS ISSUES..... 13
    - 2.5.6. TRAFFIC CONTROL..... 14
    - 2.5.7. PARALLEL LOW-PRESSURE LINE ..... 16
    - 2.5.8. SHORING PLAN..... 16
    - 2.5.9. GEOTECHNICAL ENGINEERING ..... 16
    - 2.5.10. BYPASS PUMPING REQUIREMENTS ..... 16
    - 2.5.11. PERMITTING REQUIREMENTS ..... 16
    - 2.5.12. CONSTRUCTION COSTS..... 16
- SECTION 3. COST ANALYSIS ..... 17**
  - 3.1. PROJECT COST ESTIMATE ..... 17
  - 3.2. INDIVIDUAL LOW PRESSURE SUMP PUMPS ..... 17
  - 3.3. COST ASSUMPTIONS ..... 17
  - 3.4. ADDITIONAL PROJECT COSTS ..... 18
    - 3.4.1. ENGINEERING DESIGN..... 18
    - 3.4.2. LEGAL ..... 18
    - 3.4.3. ENVIRONMENTAL PERMITTING..... 18
    - 3.4.4. CONSTRUCTION MANAGEMENT ..... 18
    - 3.4.5. PROJECT ADMINISTRATION ..... 19
- SECTION 4. ENVIRONMENTAL PERMITTING ASSESSMENT ..... 20**
- SECTION 5. CONCLUSION AND RECOMMENDATIONS ..... 21**



5.1.	CONCLUSION.....	21
5.2.	RECOMMENDATION .....	21
<b>APPENDIX A. HYDRAULIC MODEL .....</b>		<b>22</b>
<b>APPENDIX B. ENVIRONMENT ONE GRINDER PUMP .....</b>		<b>23</b>
<b>APPENDIX C. PROPOSED PROJECT COST ESTIMATE.....</b>		<b>24</b>
<b>APPENDIX D. BIOLOGICAL ALTERNATIVES ANALYSIS .....</b>		<b>25</b>



## Section 1. Project Overview

### 1.1. Objective

The goal of this Preliminary Engineering Study is to evaluate two alternatives for replacing an existing sewer main within the Carmel Area Wastewater District (District) wastewater collection system.

### 1.2. Setting

The section of sewer main to be replaced is located in and parallel to Pescadero Road on the northwest side of the City of Carmel-by-the-Sea (City) in Monterey County, California. The pipeline and associated manholes were installed approximately 80 years ago. The existing alignment runs to the west of a row of residential properties along the west side of Pescadero Road. The sewer main crosses several properties along the existing alignment to be replaced including private residential properties and property owned by the Del Monte Forest Conservancy, designated as the Pescadero Canyon Property. The ground surface in this area is steeply sloped from the east to the west, unstable, and currently inhabited by various plant and animal species, including Monterey pines and coast live oaks. The existing sewer main runs upslope from, and parallel to, the Pacheco Creek riparian corridor.

### 1.3. Existing Collection System and Properties Served

The existing sewer main on the forested hillside in the Pescadero Canyon Property has been damaged by tree falls and is in poor condition. Localized high points and other condition issues have caused several sanitary sewer overflows, and maintenance crews have had difficulty accessing the sewer main for maintenance. Frequent maintenance is required due to its poor condition.

The existing gravity sewer main to be replaced is believed to have been constructed in the 1930s or 1940s and is constructed of 6-inch vitrified clay pipe (VCP). Record drawings of the existing sewer main are not available. The sewer main conveys wastewater from an estimated 275 parcels, primarily residential, within the District's service area. Of these parcels, 19 are located along Pescadero Road and have service laterals directly connected to the sewer main to be replaced. The section of sewer main to be replaced begins at District manhole N601, located within the roadway near 24652 Pescadero Road. From this point, it extends from Pescadero Road to the west, inside of the property line at 24652 Pescadero Road (APN 009-112-013) to manhole N602, then turns south in the Pescadero Canyon Property (APN 008-161-009); five manholes and approximately 1,600 linear feet of sewer main lie within the Pescadero Canyon Property. The segment to be replaced terminates on a private property at the north of Toyon Heights (APN 009-122-012) at manhole N609. The existing sewer main is shown in Figure 1.

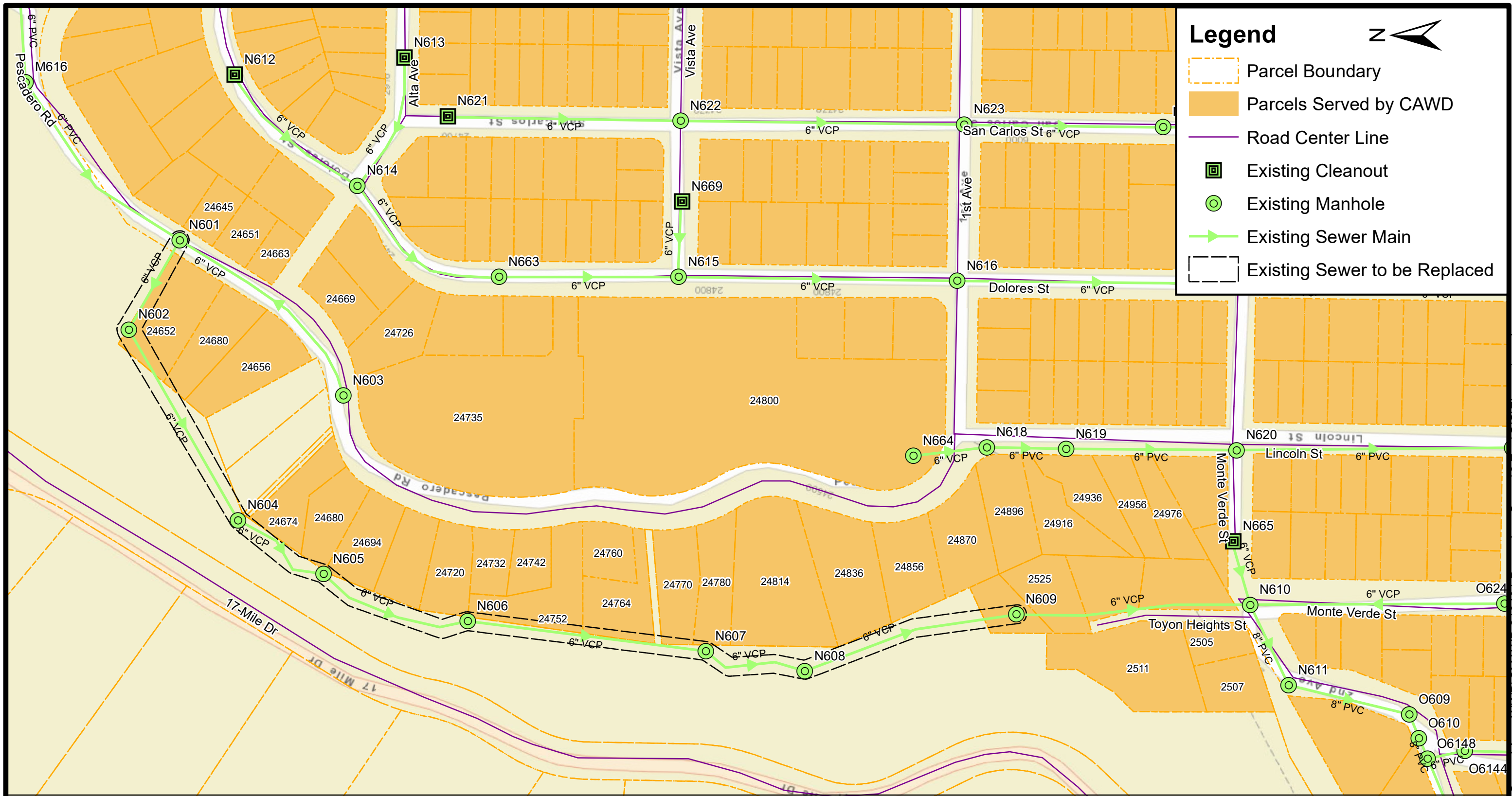
### 1.4. Project Goal

Replacing the damaged sewer main is necessary to continue to provide reliable service to the District's customers and minimize the potential for sanitary sewer overflows in the future. The criticality of this segment is elevated due to its proximity to the Pacheco Creek Riparian Corridor. The new sewer main will:

- Be designed and constructed in accordance with current District standards
- Increase the reliability and carrying capacity of the respective branch of the District's sanitary sewer system
- Reduce the potential for sanitary sewer overflows
- Reduce maintenance requirements

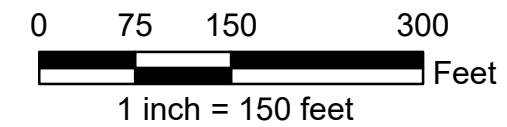






**FIGURE 1: EXISTING SEWER MAIN ALIGNMENT  
PESCADERO ROAD SEWER REPLACEMENT PROJECT  
CARMEL AREA WASTEWATER DISTRICT**

Drawn By: JAD  
 Checked By: NEP  
 QC: TNH



Project No.  
CMAWD.210401.00  
 Figure No.  
**1**

C:\Box\Projects\CMAWD Carmel Area WWD\CMAWD.210401 Pescadero Sewer2 Eng\GIS\Figure 1.mxd



## 1.5. Alternatives

Two alternatives will be considered for the replacement of the sewer main. The first alternative alignment (Alternative A) approximately follows the existing alignment in the hillside of the Pescadero Canyon Property; the second alternative alignment (Alternative B) follows Pescadero Road in the City right-of-way.



## Section 2. Preliminary Engineering

### 2.1. Design Criteria

The following criteria were used in developing the proposed infrastructure improvements to the District's wastewater collection system in accordance with District standards:

- Minimum diameter for gravity sewers: 8-inch
- Minimum slope for 8-inch pipe: 0.0034 ft/ft
- Minimum slope for 10-inch pipe: 0.0025 ft/ft
- Minimum slope for 12-inch pipe: 0.0020 ft/ft
- PVC SDR 26 to be used for all gravity sewer lines installed using open trench method
- Manning's roughness coefficient of 0.010 for PVC
- Minimum pipe velocity of 2.0 ft/sec
- Vertical drop across manhole: 0.1 feet
- Minimum manhole depth: 4 feet
- No curved gravity sewers will be allowed
- Maximum distance between manholes: 400 feet
- Maximum design capacity of gravity sewers occurs when depth divided by diameter (d/D) equals 0.5

### 2.2. Existing and Future Flows

Flow data were recorded from December 10 through December 14, 2014, by a temporary flow meter installed at manhole N609. During this monitoring period, a storm event occurred, which resulted in a significant increase in sewer flow rates. The flows were recorded during the storm event specifically to determine the peak flow rate through the section of the sewer main to be replaced. The peak flow rate recorded over the four-day period was 373 gallons per minute (GPM) and the minimum flow rate was recorded was 10 GPM. A rapid rise in sewer flow rates exhibited by the collected sewer flow data indicates high levels of inflow into the sewer system.

The sanitary sewer collection system upstream of the Project area is mostly built out; only a handful of parcels within the District's service area upstream of the sewer to be replaced are vacant. For this reason, future flows are not projected to significantly increase compared to existing flows, and the recent flow data is sufficient for the sewer main hydraulic model analysis. With proactive system management, it is possible peak sewer flow rates may decrease in the future as the District works to eliminate cross connections between storm drains and the sanitary sewer and other upgrades to reduce inflow and infiltration.

Based on the measured flow rates and anticipated stability or decrease in future sewer flow rates, a design flow rate of 400 GPM is recommended for this segment of sewer.

### 2.3. Pipe Sizing

Minimum pipe size and slope were determined by calculating hydraulic capacity. Utilizing a peak flow rate of 400 GPM, and the District standard requirements documented in Section 2.1, minimum slopes for multiple pipe sizes were calculated. These values are shown in Table 1.





**Table 1: Minimum Sewer Slope**

Nominal Pipe Size (in)	Flow Rate (GPM)	Hydraulically Calculated Minimum Slope (ft/ft)	District Standard Minimum Slope (ft/ft)
8	400	0.0152	0.0034
10	400	0.0046	0.0025
12	400	0.0018	0.0020

Based on the results of this calculation, if 8-inch or 10-inch pipe is utilized, it will need to be installed with a slope greater than the minimum allowed by District standards to maintain sufficient capacity.

## 2.4. Alternative A Conceptual Design

### 2.4.1. Alternative A Description

Alternative A would demolish and remove the existing sewer main and manholes to be replaced and construct a new 8-inch polyvinyl chloride (PVC) gravity sewer main and manholes along a similar alignment as the existing 6-inch sewer main. The final alignment would extend from manhole N601 to manhole N609, north of Toyon Heights. Manhole N601 would be demolished and removed, and a new manhole constructed in Pescadero Road to the north to allow for a 10-foot buffer between the property line at 24652 Pescadero Road and the proposed 8-inch sewer main. The short sewer segment that flows within the roadway from manhole N603 to manhole N601 from the south would be extended to reach this new manhole. The proposed alignment for Alternative A is shown on Figure 2. In total, approximately 1,800 linear feet of new 8-inch PVC pipe and eight manholes are required to direct flow from manhole N601 to manhole N609.

A 20-foot-wide access path along the alignment in vegetated areas would be cleared and grubbed of all vegetation and graded to provide a drivable surface in vegetated areas. The temporary path would allow for equipment access for the construction of the new sewer. This includes removal of trees, brush, and other plants in this area. Significant retaining walls would likely be required along the construction path for construction and permeant access along the alignment.

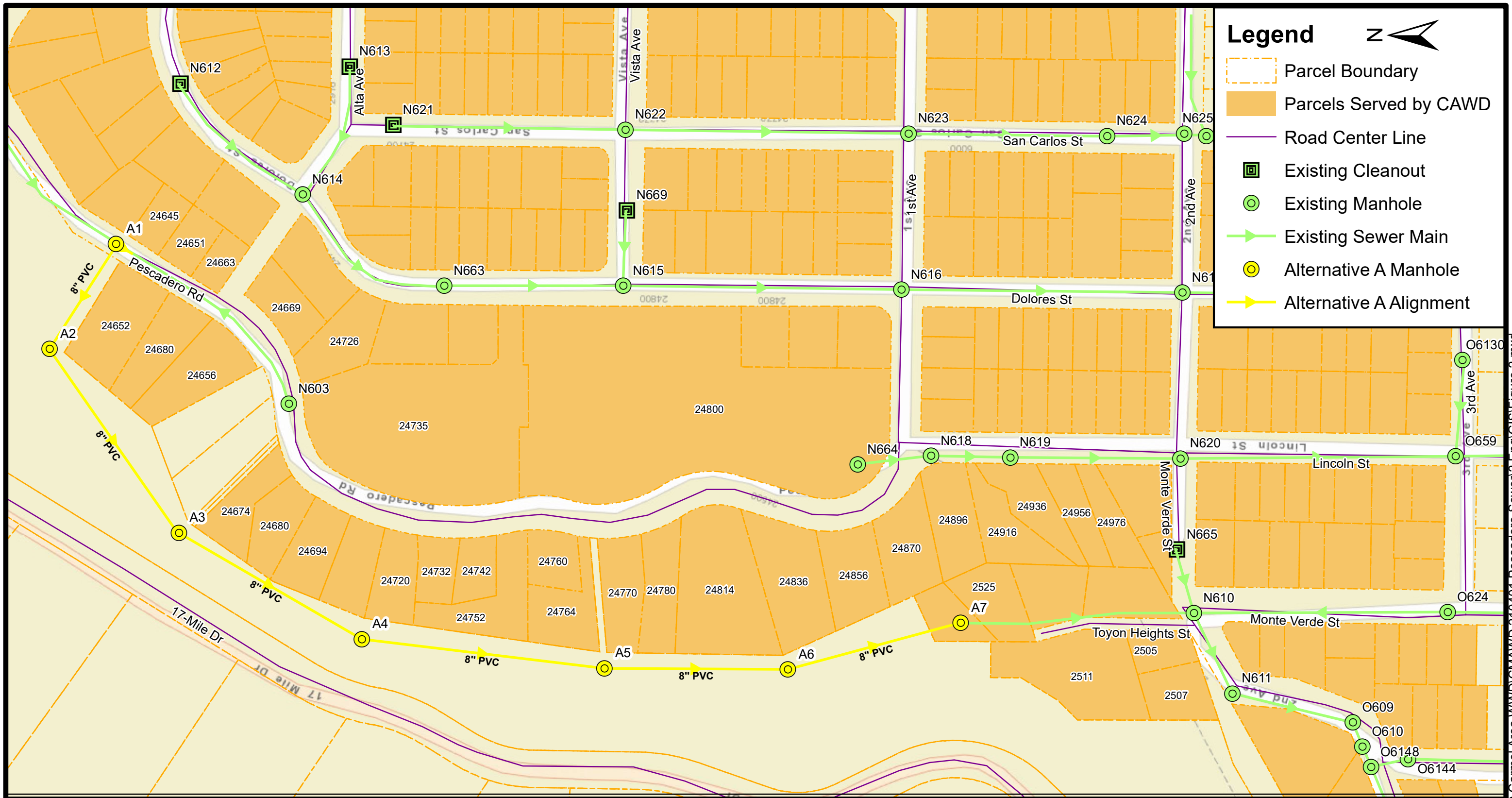
The pipeline would be constructed by the open trench method, with approximate trench depths ranging from 4 feet to 10 feet below the surface of the graded path and roadway. Individual property sewer laterals would be reconnected from the residence property lines to the new sewer main. In unpaved areas, the trench would be backfilled with crushed rock surrounding the sewer main and with native or imported material to bring the trench up to grade. Through paved areas, the trench will be backfilled with only crushed rock or Class II aggregate base, and the trench repaved in accordance with County standards. Manholes would be constructed of polymer concrete per District standards. Construction activities for manholes will be limited to the 20-foot wide access path for construction of the sewer main.

### 2.4.2. Hydraulic Analysis

Limited ground elevation data for the Alternative A alignment was available for this study. Approximate rim elevations were based on topographic information using Google Earth. Field measured invert elevations at upstream manhole N601 and downstream manhole N610 were used as the basis of a hydraulic model, included as Appendix A. The average slope between the inverts of these two manholes is roughly 0.05 ft/ft. Based on the minimum slopes documented in Table 1, an 8-inch diameter PVC pipe will provide sufficient flow capacity to carry the design flow rate of 400 GPM with a minimum slope of 0.0152 ft/ft. If a minimum slope of 0.0152 ft/ft is not feasible along segments of the alignment, an increase in pipe size may be required.





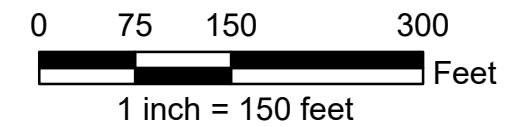


**Legend**

- Parcel Boundary
- Parcels Served by CAWD
- Road Center Line
- Existing Cleanout
- Existing Manhole
- Existing Sewer Main
- Alternative A Manhole
- Alternative A Alignment

**FIGURE 2: ALTERNATIVE A - HILLSIDE ALTERNATIVE  
PESCADERO ROAD SEWER REPLACEMENT PROJECT  
CARMEL AREA WASTEWATER DISTRICT**

Drawn By: JAD  
Checked By: NEP  
QC: TNH



Project No.  
CMAWD.210401.00  
Figure No.  
**2**

C:\Box\Projects\CMAWD Carmel Area WWD\CMAWD.210401 Pescadero Sewer\2 Eng\GIS\Figure 2.mxd



### 2.4.3. Real Property Issues

The existing and proposed Alternative A alignment traverses several private properties. At the time of writing, documentation of easements across all of these properties have not been obtained. Only documents describing a 20-foot wide easement along Toyon Heights have been obtained.

While easement information has not been obtained for all private properties impacted by this alignment, it is believed existing easements will be insufficient for construction of Alternative A. The Alternative A alignment will be realigned from the existing alignment in some locations, which is anticipated to necessitate permanent easement modifications. In addition, temporary access easements, and abandonment of existing easements which would no longer be required are recommended.

A summary of the private properties impacted by Alternative A are documented in Table 2.

**Table 2: Real Properties Affected by Existing and Proposed Sewer Main**

Impacted Property Address (APN)	Temporary Access Easement Required	Permanent Access Easement Modification Required	Potential to Relinquish Existing Easement
24652 Pescadero Rd (009-112-013)	Yes	No	Yes
Pescadero Canyon Property (008-161-009)	Potentially	Yes	No
Unknown Address on Toyon Heights (009-122-012)	Potentially	Potentially	No
Unknown Address on Toyon Heights (009-122-010)	No	No	No
Unknown Address on Toyon Heights (009-122-009)	No	No	No
2505 2 <sup>nd</sup> Ave. (009-122-025)	No	No	No
2511 2 <sup>nd</sup> Ave. (009-122-013)	No	No	No
2525 2 <sup>nd</sup> Ave. (009-122-011)	Potentially	Potentially	No

Although the proposed alignment for Alternative A runs outside of the property at 24652 Pescadero Road, a temporary easement will be required for the removal of the existing sewer infrastructure.



#### 2.4.4. Geotechnical Engineering

Due to the significant amount of grading required to provide access for sewer main construction, geotechnical borings and associated analysis is recommended during detailed design to provide additional information for the contractor to accurately budget for earth movement and slope stability. Due to the rough terrain, borings would need to be completed by a track mounted drilling rig, and some portions of the alignment are likely inaccessible even with tracked equipment.

#### 2.4.5. Access Issues

The steep, unstable slopes in the area of the proposed alignment requires significant site improvements to allow for construction of the new sewer main and manholes. Clearing and grubbing activities will be required, including the removal of several trees. Grading a 20-foot-wide path on the hillside is recommended to allow for equipment access. Section 2.4.3 includes a discussion of temporary construction access easements required for the construction of Alternative A. Section 4 includes an assessment of the environmental impacts associated with Alternative A.

#### 2.4.6. Traffic Control

During construction, minor impacts to Toyon Heights (the private drive extending north from the corner of 2<sup>nd</sup> Avenue and Monte Verde Street) would be impacted for access of construction equipment but would be anticipated to remain open during construction.

Pescadero Road would be closed to all vehicle traffic during working hours for the relocation of manhole N601. Traffic would be rerouted through a detour spanning 1<sup>st</sup> Avenue, Dolores Street, and Castro Lane. All excavations would also be plated, and the roadway reopened to traffic at the end of each working day.

#### 2.4.7. Bypass Pumping Requirements

Bypass pumping would be required during construction to convey wastewater around the work area. A temporary bypass pipeline would be constructed on grade parallel to the existing sewer main. Bypass pumps, located on Pescadero Road near existing manhole N601, would be required during daytime working hours for the construction of the new line, for an estimated period of one month. These pumps would pump wastewater through the temporary pipeline until the new sewer main is installed and ready for use. During nighttime hours and weekends, the contractor could temporarily reconnect the main line to convey wastewater through the work area using the existing sewer main to avoid bypass pumping during non-working hours. These pumps are typically powered by a gas-powered generator or direct gas-powered drive. They typically output 66 decibels at a distance of 10 feet and 63 decibels at a distance of 20 feet. In addition, isolated short term bypass pumps will be located on individual laterals as needed.

It is recommended a conceptual bypassing plan be prepared during the design process.

#### 2.4.8. Permitting Requirements

Portions of the work included in Alternative A occur within County right-of-way; as a result, an encroachment permit from the County would need to be obtained. For environmental permitting, see Section 4. For issues associated with easements, see Section 2.4.3.

#### 2.4.9. Construction Costs

A detailed description of the anticipated project construction costs for Alternative A are included in Section 3.



## 2.5. Alternative B Conceptual Design

### 2.5.1. Alternative B Description

Alternative B would abandon the existing sewer main to be replaced and construct a new 10-inch PVC gravity sewer main within the Pescadero Road, Lincoln Street, and Monte Verde Street right-of-way. The proposed alignment would reconfigure existing upstream manhole N601 and connect a new gravity sewer to existing downstream manhole N610 with new 10-inch PVC gravity sewer. The existing sewer segment between manhole N601 and manhole N603 would be demolished and removed. Flow along this segment would be reversed with installation of the new gravity sewer. Existing manholes and sewer between manhole N618 and N620 would be demolished and removed, and the new sewer constructed in their place. Between manhole N620 and N610, the proposed alignment will travel through the cul-de-sac on Monte Verde Street and continue to manhole N610 below. The new sewer would be constructed using open trench construction. In total, approximately 2,210 linear feet of new 10-inch sewer main and 11 manholes would be constructed. Figure 3 shows the proposed alignment for Alternative B.

Trench excavation depths are anticipated to range between 6 and 22 feet below grade. An approximate profile of the alignment is shown in Figure 4. Pipeline trenches would be backfilled with crushed rock and/or Class II aggregate base and paved, except in unimproved areas. As in Alternative A, manholes would be constructed of precast polymer concrete per the District standards.

Reconfiguring existing manhole N601 several feet upstream to a slightly higher elevation and minimizing the manhole depth could reduce excavation costs in the area immediately downstream of this manhole where the gravity sewer main could reach depths of 22 feet below grade. This option will be considered if Alternative B is selected by the District.

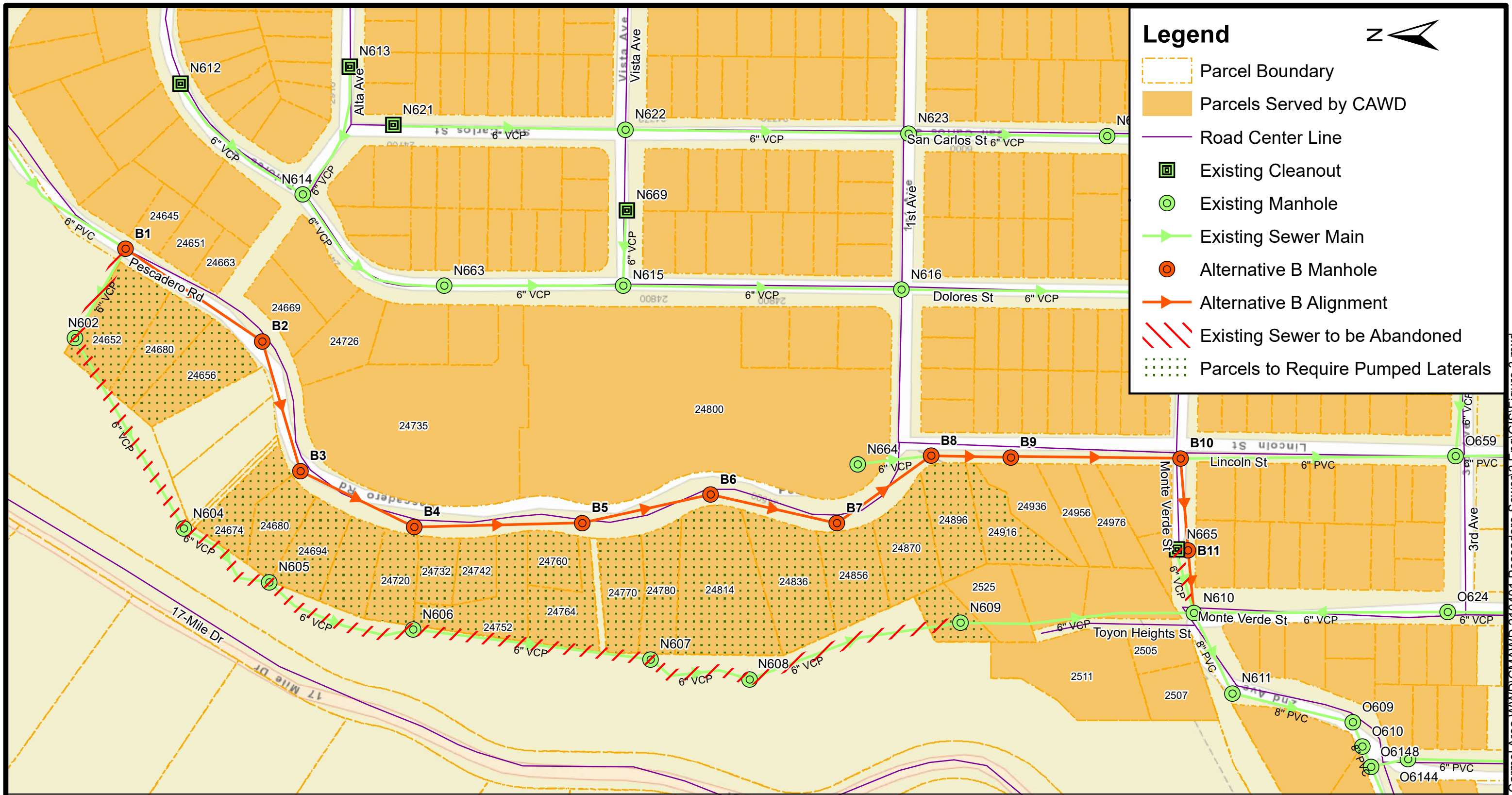
Due to the elevation difference between the Alternative B alignment and the existing residence sewer laterals downhill from Pescadero Road, a low-pressure grinder sump pump would be required on the downhill side of each residence to convey wastewater to the sewer main in the roadway. Discharge piping from each sump pump will be installed approximately three feet below grade within the private property to the public right-of-way. Each low-pressure sump pump would be owned and maintained by the individual property owner. To reduce excavation costs in areas where the gravity sewer main would reach beyond a specified depth, a 2-inch-diameter low-pressure line would be installed parallel to the gravity sewer main to carry the effluent from the grinder pump systems to the nearest manhole, at which point the low-pressure system would discharge into the manhole and be carried by the gravity main downstream. This is intended to simplify future access for maintenance.

The individual property owners owning the low-pressure sump pumps presents challenges associated with the installation of these systems. In an effort to limit the District's liability, the District may require residences requiring pumped laterals to independently hire a contractor to install these systems and reimburse the homeowners for the cost of their installation. Estimated installation costs for the system are detailed in Section 3. The properties which would require the installation of a grinder pump system are shown on Figure 3. The Environment One (E/One) DH071 grinder pump has been used as the basis for the conceptual design of Alternative B. More information on the E/One grinder pump system is included as Appendix B.









**Legend**

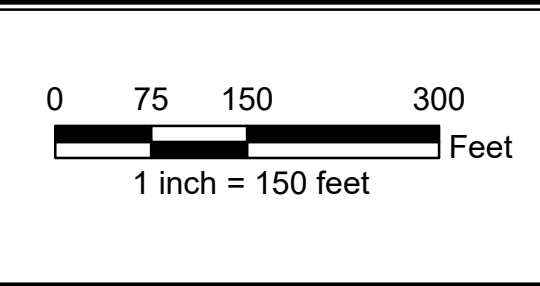
- Parcel Boundary
- Parcels Served by CAWD
- Road Center Line
- Existing Cleanout
- Existing Manhole
- Existing Sewer Main
- Alternative B Manhole
- Alternative B Alignment
- Existing Sewer to be Abandoned
- Parcels to Require Pumped Laterals



Drawn By: JAD  
 Checked By: NEP  
 QC: TNH



**FIGURE 3: ALTERNATIVE B - ROADWAY ALTERNATIVE  
 PESCADERO ROAD SEWER REPLACEMENT PROJECT  
 CARMEL AREA WASTEWATER DISTRICT**



Project No.  
 CMAWD.210401.00  
 Figure No.  
**3**

C:\Box\Projects\CMAWD Carmel Area WWD\CMAWD.210401 Pescadero Sewer2 Eng\GIS\Figure 3.mxd





In addition to the construction of the new sewer, the existing sewer would need to be properly abandoned. Abandoning the existing sewer manholes in accordance with District standards involves fracturing the base of the manholes, salvaging the manhole frame and cover, removing the top of the manhole to a minimum depth of 24 inches below grade, and filling the remaining manhole barrels and sewer main with 1-sack slurry. Sewer mains would also be filled with 1-sack slurry or cellular concrete. This work would be completed using hand and power tools carried on foot from Pescadero Road and Toyon Heights. Hoses and cords from Pescadero Road would be required to convey concrete and power equipment, which would be laid on grade to accomplish this work. Provisions would be set in place to prevent any slurry or other materials from spilling from the sewer main and manholes to the surrounding areas. No wheeled or tracked equipment would be allowed outside the public right-of-way. Figure 3 shows the sections of the existing sewer that would be abandoned.

### 2.5.2. Trenchless Sewer Installation

Installation of portions of the sewer main using trenchless installation methods, specifically HDD, was evaluated for all segments of the alignment for Alternative B. This method was considered to reduce the costs and risks associated with excavating deep trenches. The equipment used for HDD is able to install HDPE pipe on a curve with a minimum radius of 600 feet. Several curved sections of Pescadero Road have a radius much smaller than 600 feet; therefore, deep excavations would still be necessary to install multiple straight runs of pipe to navigate the bends in the roadway. The District could consider allowing HDD installation of some additional pipe segments; however, this is not expected to provide a significant cost savings.

### 2.5.3. Hydraulic Model

For the purposes of this study, a field survey was performed to confirm the sewer could flow by gravity through Pescadero Road from existing manhole N601 to N618, and to establish required pipeline depths. The survey estimated an approximate total drop of 42 feet between the manhole inverts. An approximate profile of the alignment is shown in Figure 4. However, where high points in the road are located, sewer depths would exceed 20 feet. To minimize trenching costs, maintaining minimum slope is recommended, where appropriate. The collected elevation data, along with the constraints described in Section 2.2, were used to prepare a hydraulic model for Alternative B, included as Appendix A. To minimize trenching costs by maintaining a minimum slope, while providing sufficient capacity during 400 GPM peak flow events, a 10-inch diameter PVC pipe is recommended for this alternative. For the use of a 10-inch pipe, maintaining a minimum slope of 0.0046 ft/ft is required, as described in Section 2.3.

Note that this will result in a decrease in sewer main size at manhole N610 from 10-inch to 8-inch sewer.

### 2.5.4. Real Property Issues

The proposed alignment for Alternative B rests entirely within the public right-of-way along Pescadero Road, Lincoln Street, and Monte Verde Street, and therefore, no permanent access easements would be necessary for the installation or future work on the sewer. However, during the abandonment of the existing sewer infrastructure, temporary construction access easements will be required for the property at 24652 Pescadero Road (APN 009-112-013) and the Pescadero Canyon Property (APN 008-161-009). If Alternative B is selected, the District should consider relinquishing easements along the existing sewer alignment.

### 2.5.5. Access Issues

Construction of the proposed sewer main for Alternative B would be kept entirely in the public right-of-way, with access via paved roadways. Abandonment activities are expected to be completed using hand and power tools carried on foot to the existing sewer; therefore, no wheeled or tracked equipment would require access outside of the public right-of-way. Access to the existing sewer for abandonment would be achieved through existing or temporary easements if required.



### 2.5.6. Traffic Control

During construction, portions of Pescadero Road, Lincoln Street, and Monte Verde Streets in the vicinity of the work would be closed to all vehicle and pedestrian traffic during working hours. Traffic would be routed around the work area through 1<sup>st</sup> Avenue, Dolores Street, and Castro Lane. At the end of each working day, all excavations would be plated, and the roadway reopened to traffic.



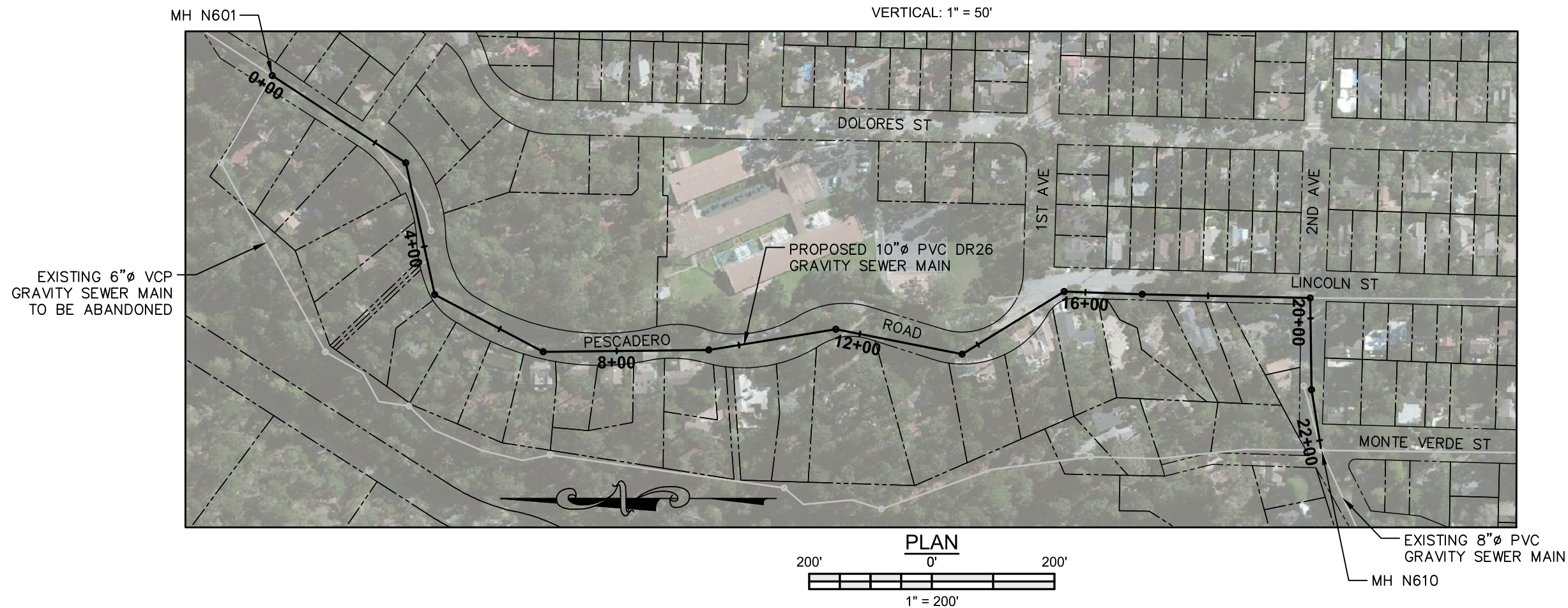
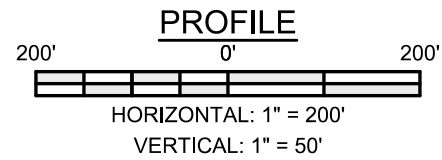
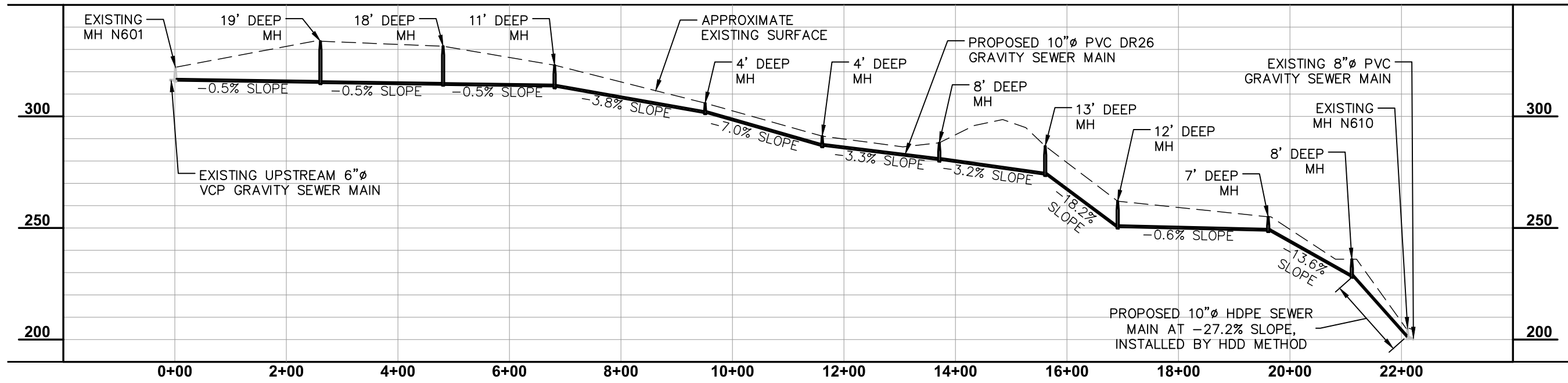


FIGURE 4: ALTERNATIVE B - ROADWAY ALIGNMENT PLAN AND PROFILE  
 PESCADERO ROAD SEWER REPLACEMENT  
 CARMEL AREA WASTEWATER DISTRICT



### 2.5.7. Parallel Low-Pressure Line

To reduce excavation costs for connecting sewer laterals at locations in the alignment which reach a certain depth, 2-inch low-pressure lines will be considered. The low-pressure line would collect effluent from each individual property's grinder pump system discharge piping at the property line and run in the City's right-of-way parallel to the nearest gravity sewer main at a depth approximately three feet below grade. The low-pressure line would discharge into the nearest manhole through a drop inlet, and the wastewater would continue downstream through the new 10-inch gravity sewer main. This system may increase the required total dynamic head from each property's grinder pump system but would reduce excavation costs associated with connecting sewer laterals to deep sections of the sewer main.

### 2.5.8. Shoring Plan

Trenches in some areas will exceed 20 feet in depth. A shoring plan prepared, stamped and signed by a licensed civil engineer would be required from the contractor prior to the start of excavation.

### 2.5.9. Geotechnical Engineering

Due to the deep trench excavations anticipated along the alignment, geotechnical borings and analysis is recommended during detailed design to provide a basis for a shoring plan and to provide additional information for the contractor to accurately budget for deep excavations.

### 2.5.10. Bypass Pumping Requirements

Bypass pumping will be required during construction to convey wastewater around the work area. Bypass pumps, located on Pescadero Road, would be required 24-hours per day during the construction of the new manhole to replace the existing manhole N601 for an estimated 5-day period. These pumps are typically powered by a gas-powered generator or direct gas-powered drive. They typically output 66 decibels at a distance of 10 feet and 63 decibels at a distance of 20 feet. In addition, isolated short term bypass pumps will be located on individual laterals as needed.

### 2.5.11. Permitting Requirements

Portions of the work included in Alternative B occur within City of Carmel-By-the-Sea and County right-of-way; as a result, encroachment permits from both agencies would need to be obtained. For environmental permitting requirements, see Section 4. For issues associated with easements, see Section 2.5.4.

### 2.5.12. Construction Costs

See Section 3 for a detailed description of the anticipated project construction costs for Alternative B.





## Section 3. Cost Analysis

### 3.1. Project Cost Estimate

A budgetary cost estimate was developed to estimate anticipated construction costs associated with the proposed infrastructure for each alternative. Detailed cost estimates are included as Appendix C. A summary of the cost estimates for the two alternatives are shown in Table 3. Section 3.3 provides assumptions made in the estimates.

**Table 3: Summary of Estimated Cost of Construction**

	Alternative A	Alternative B
<b>Construction Cost</b>	\$2,640,000	\$1,530,000

### 3.2. Individual Low Pressure Sump Pumps

In addition to the baseline cost of construction for each alternative incurred by the District, shown in Table 3, selection of Alternative B would incur additional costs associated with individual low-pressure sump pump systems. A summary of this additional cost is shown in Table 4. This cost estimate includes the purchase of the E/One DH071 grinder pump and lateral valve kit, and the installation of these items; the estimate does not include additional improvements specific to each property, such as household electrical wiring modifications, landscaping repair, decking demolition and repair, etc.

**Table 4: Individual Low Pressure Sump Pump Costs**

	Alternative A	Alternative B
<b>Number of Low Pressure Pump Systems Required</b>	0	19
<b>Cost Incurred By Each Property Owner</b>	\$0	\$14,000
<b>Total Cost</b>	\$0	\$266,000

### 3.3. Cost Assumptions

The following assumptions were included in the development of these costs:

- Unit costs developed for these cost estimates are included in Appendix C.
- Sewer main alignment and manhole locations were determined based on assessor’s parcel map information and District GIS maps. Actual roadway alignments may require additional manholes and modifications to the pipeline alignments.
- Pipe depth was classified into three tiers: Shallow at 4’-8’, Medium at 8’-14’, and Deep at 14’-24’.
- Manhole depths were divided into 8 tiers based on depths.
- For gravity sewer connections, the Project includes installation of individual sewer laterals from the sewer main to a new property line cleanout and connection to existing sewer laterals for gravity sewer laterals.





- Cost estimates for gravity sewer laterals do not include any costs incurred by the property owner for connecting to the sewer laterals at the property line.
- Since all customers are currently connected to the collection system, no connection fees will be assessed as part of this project.
- No manhole linings will be provided on new or existing manholes.
- Manhole frames and covers will be per District standards.
- Pavement trench section is in accordance with District, County, and City of Carmel-By-The-Sea standards.
- Easements for the construction of the project will be obtained at no cost to the District.

### 3.4. Additional Project Costs

In addition to the costs associated with construction of the proposed improvements, costs for each alternative will be incurred by the project associated with engineering design, easement modifications, legal, public outreach, environmental permitting, construction management, and overall administration of the project.

Detailed estimates of the costs associated with each of these elements have not been developed as part of this preliminary engineering report, except for environmental permitting, but should be considered by the District in preparation of this project. A discussion of the scope associated with each of these additional costs are provided in the following sections.

#### 3.4.1. Engineering Design

Engineering design includes development of complete contract documents for the project including the following tasks:

- Project management and coordination
- Topographic survey of the project area
- Development of legal descriptions for the acquisition of easements
- Geotechnical testing and analysis
- Detailed design of all proposed improvements
- Bid support services
- Engineering support during construction

#### 3.4.2. Legal

Legal includes all costs associated with the legal review and compliance associated with the project including obtaining and establishing funding mechanisms for the project, and land/easement acquisition.

#### 3.4.3. Environmental Permitting

Environmental permitting includes costs incurred by the District associated with obtaining, and compliance with environmental requirements for this Project. See Appendix D for a summary of the anticipated environmental permitting costs associated with the Project.

#### 3.4.4. Construction Management

Construction management includes costs associated with comprehensive management of the construction of the proposed improvements. This includes:



- District representation
- Construction inspection and testing services
- Construction scheduling and controls
- Change order management
- Dispute resolution
- Progress meetings
- Environmental compliance documentation
- Project documentation
- Start-up, testing, and acceptance
- Final construction summary reporting

#### 3.4.5. Project Administration

Project Administration includes costs incurred by the District associated with the internal management of the Project including District's staff time and other direct expenses.



## Section 4. Environmental Permitting Assessment

A Biological Alternatives Analysis was prepared by Denise Duffy and Associates, Inc., to compare the biological resources which may be impacted by the two alternative alignments. This analysis also identifies future biological surveys and regulatory permits that may be required for each alternative alignment. The full analysis memorandum is included as Appendix D.

The analysis concludes that the existing sewer main to be replaced lies in an environmentally sensitive habitat area potentially inhabited by special-status plant and animal species, which elicits the need for a more focused survey to identify the presence or absence of these species. The area is also subject to the Del Monte Forest and Carmel Area Land Use Plans.

As Alternative A approximately follows the existing sewer main alignment, permits will be required to construct the new sewer main. A Coastal Development Permit would be required by the Coastal Commission, and an Initial Study/Mitigated Negative Declaration would be required for compliance with the California Environmental Quality Act (CEQA).

The Alternative B alignment within the roadway would have less-than-significant effects on the potential special-status species identified in the biological alternatives analysis. Potential impacts to these species would be identified and avoided. Due to its nature, Alternative B could be exempt from both Coastal Development Permit and CEQA requirements but would require the issuance of these exemptions from their respective jurisdictions.

Based on the analysis, Alternative B would be the biological preferred alignment.



## Section 5. Conclusion and Recommendations

### 5.1. Conclusion

Based on the available information and preceding analysis, a matrix was created to compare Alternatives A and B in several main categories. The matrix is shown in Table 5.

**Table 5: Project Alternatives Matrix**

Category	Alternative A	Alternative B
<b>Construction Cost</b>	\$2,640,000	\$1,530,000
<b>Private Pumped Laterals Required (Cost)</b>	No	Yes (\$266,000)
<b>Environmental Permitting Process Duration</b>	Many Months – 12+ Months	Brief – 3 Months
<b>Environmental Permitting Costs</b>	High	Low
<b>Environmental Compliance Cost</b>	High	Low
<b>Impact to Residents</b>	Extended sewer bypassing period, minimal effects on traffic control and road closures	Short sewer bypassing period, full road closure to Pescadero Road for an extended period
<b>Additional Easements Required?</b>	Yes	No

Legend

- Favorable
- Neutral
- Unfavorable

### 5.2. Recommendation

The recommended project was selected based on improvement alternatives and discussion with the District. Alternative B is the recommended alternative. As shown in Table 5 above, Alternative B presents multiple short and long term benefits to the District.



## Appendix A. Hydraulic Model







ENGINEERS INC

**Carmel Area Wastewater District**

**Pescadero Road Sewer Main Replacement - Alternative A Hydraulic Analysis**

Calculation By: SPP

Checked By: NEP

Manhole	Approx. Rim Elev. (ft)	MH Invert In (ft)	MH Invert Out (ft)	MH Depth (ft)	Pipe	Length (ft)	Slope (ft/ft)	Pipe Elev. Outlet (ft)	Pipe Elev. Inlet (ft)	Pipe I.D. (in)	Pwet 50% (ft)	A 50% (ft <sup>2</sup> )	v 50% (ft/s)	50% Capacity (gpm)	100% Capacity (gpm)
A1 (N601)	322.0	316.1	316.0	5.9											
					1	200	0.0511	*	316.0	7.754	1.015	0.163964	10.0	733.3	1466.7
A2	*	*	*	*											
					2	360	*	*	*	7.754	1.015	0.163964	*	*	*
A3	*	*	*	*											
					3	340	*	*	*	7.754	1.015	0.163964	*	*	*
A4	*	*	*	*											
					4	390	*	*	*	7.754	1.015	0.163964	*	*	*
A5	*	*	*	*											
					5	290	*	*	*	7.754	1.015	0.163964	*	*	*
A6	*	*	*	*											
					6	290	*	*	*	7.754	1.015	0.163964	*	*	*
A7	*	*	*	*											
					7	200	*	*	*	7.754	1.015	0.163964	*	*	*
A8	*	*	*	*											
					8	180	*	201.0	*	7.754	1.015	0.163964	*	*	*
N610	205.0	201.0	200.9	4.1											

2250.0

\* Hillside elevation data unavailable for this model.

Total Drop Inv.= 115.0 ft

Total Length= 2250.0 ft

Avg. Slope= 0.05111111 ft/ft



ENGINEERS INC

**Carmel Area Wastewater District**

**Pescadero Road Sewer Main Replacement - Alternative B Hydraulic Analysis**

Calculation By: SPP

Checked By: NEP

Manhole	Approx. Rim Elev. (ft)	MH Invert In (ft)	MH Invert Out (ft)	MH Depth (ft)	Pipe	Length (ft)	Avg. Pipe Depth (ft)	Slope (ft/ft)	Pipe Elev. Outlet (ft)	Pipe Elev. Inlet (ft)	Pipe I.D. (in)	Pwet 50% (ft)	A 50% (ft <sup>2</sup> )	v 50% (ft/s)	50% Capacity (gpm)	100% Capacity (gpm)
B1	322.0	316.1	316.0	5.9												
					1	260	12.3	0.0046	314.8	316.0	9.692	1.26868	0.25617	3.474595	399.5	799.0
B2	333.5	314.8	314.7	18.8												
					2	220	17.8	0.0050	313.6	314.7	9.692	1.26868	0.25617	3.616473	415.8	831.6
B3	331.3	313.6	313.5	17.7												
					3	200	13.3	0.0050	312.5	313.5	9.692	1.26868	0.25617	3.616473	415.8	831.6
B4	322.8	312.5	312.4	10.3												
					4	270	6.3	0.0383	302.1	312.4	9.692	1.26868	0.25617	10.01356	1151.3	2302.6
B5	305.8	302.1	302.0	3.8												
					5	210	3.1	0.0698	287.3	302.0	9.692	1.26868	0.25617	13.50857	1553.2	3106.3
B6	291.0	287.3	287.2	3.8												
					6	210	5.2	0.0329	280.3	287.2	9.692	1.26868	0.25617	9.270756	1065.9	2131.8
B7	288.0	280.3	280.2	7.8												
					7	190	16	0.0316	274.2	280.2	9.692	1.26868	0.25617	9.088644	1045.0	2090.0
B8	287.0	274.2	274.1	12.9												
					8	130	12.2	0.1823	250.4	274.1	9.692	1.26868	0.25617	21.83749	2510.8	5021.6
B9	262.0	250.4	250.3	11.7												
					9	270	8.9	0.0056	248.8	250.3	9.692	1.26868	0.25617	3.812098	438.3	876.6
B10	255.0	248.8	248.7	6.3												
					10	150	7	0.1363	228.3	248.7	9.692	1.26868	0.25617	18.88432	2171.2	4342.5
B11	236.0	228.3	228.2	7.8												
					11	100.0	5.7	0.2715	201.0	228.2	9.692	1.26868	0.25617	26.64926	3064.0	6128.1
N610	205.0	201.0	200.9	4.1												

2210 ft

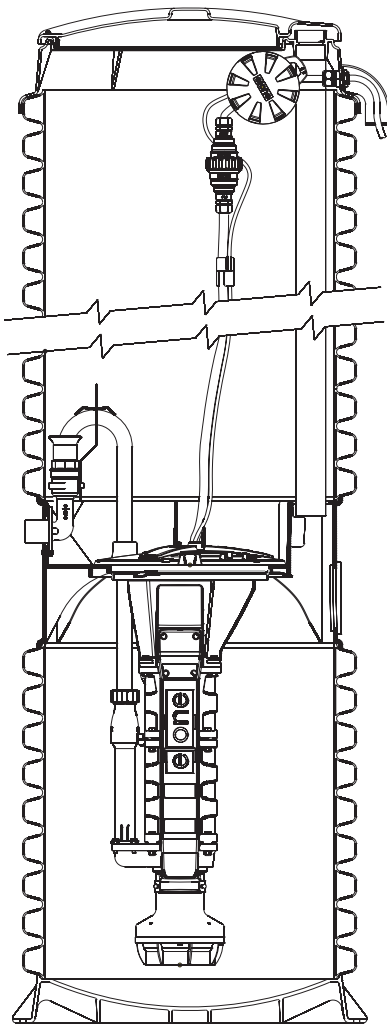


## Appendix B. Environment One Grinder Pump





## DH071/DR071



### General Features

The model DH071 or DR071 grinder pump station is a complete unit that includes: the grinder pump, check valve, HDPE (high density polyethylene) tank, controls, and alarm panel. A single DH071 or DR071 is a popular choice for one, average single-family home and can also be used for up to two average single-family homes where codes allow and with consent of the factory.

- Rated for flows of 700 gpd (2650 lpd)
- 70 gallons (265 liters) of capacity
- Indoor or outdoor installation
- Standard outdoor heights range from 61 inches to 160 inches

The DH071 is the “hardwired,” or “wired,” model where a cable connects the motor controls to the level controls through watertight penetrations.

The DR071 is the “radio frequency identification” (RFID), or “wireless,” model that uses wireless technology to communicate between the level controls and the motor controls.

### Operational Information

#### *Motor*

1 hp, 1,725 rpm, high torque, capacitor start, thermally protected, 120/240V, 60 Hz, 1 phase

#### *Inlet Connections*

4-inch inlet grommet standard for DWV pipe. Other inlet configurations available from the factory.

#### *Discharge Connections*

Pump discharge terminates in 1.25-inch NPT female thread. Can easily be adapted to 1.25-inch PVC pipe or any other material required by local codes.

#### *Discharge*

15 gpm at 0 psig (0.95 lps at 0 m)  
11 gpm at 40 psig (0.69 lps at 28 m)  
7.8 gpm at 80 psig (0.49 lps at 56 m)

### Accessories

E/One requires that the Uni-Lateral, E/One’s own stainless steel check valve, be installed between the grinder pump station and the street main for added protection against backflow.

Alarm panels are available with a variety of options, from basic monitoring to advanced notice of service requirements.

The Remote Sentry is ideal for installations where the alarm panel may be hidden from view.

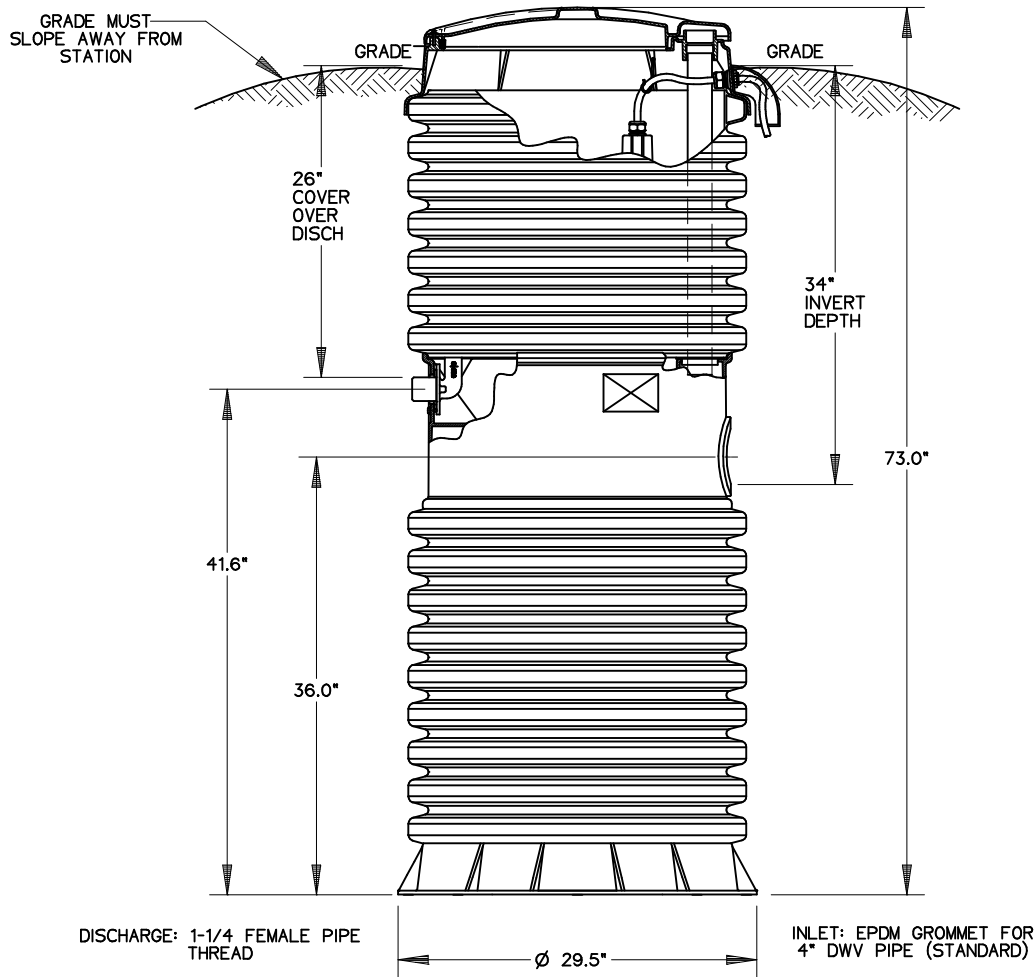
Patent Numbers: 5,752,315  
5,562,254 5,439,180

NA0050P01 Rev C

OPTIONS :  **DH071-74**  
 **DR071-74**

(HARD WIRED  
LEVEL CONTROLS)

(WIRELESS  
LEVEL CONTROLS)



CONCRETE BALLAST MAY BE REQUIRED  
SEE INSTALLATION INSTRUCTIONS  
FOR DETAILS

NOTE: DIMENSIONS ARE FOR REF ONLY



AD	CAH	07/12/07	B	1/16
DR BY	CHK'D	DATE	ISSUE	SCALE



MODEL DH071-74 / DR071-74

NA0050P05

## Appendix C. Proposed Project Cost Estimate





**OPINION OF PROBABLE CONSTRUCTION COST**



Project: Pescadero Road Sewer Replacement Project

Prepared By: JAD/NEP

Building, Area: Alternative A - Hillside Alignment

Date Prepared: 12/31/2021

MNS Proj. No. CMAWD.210401

Estimate Type:  Conceptual  Construction  
 Preliminary (w/o plans)  Change Order  
 Design Development @ \_\_\_\_\_ % complete

Current at ENR \_\_\_\_\_  
 Escalated to ENR \_\_\_\_\_  
 Months to Midpoint of Construction \_\_\_\_\_

Spec. No.	Item No.	Description	Qty.	Units	Materials		Installation		Sub-Contractor		Total
					\$/Unit	Total	\$/Unit	Total	\$/Unit	Total	
	1	Mobilization and Demobilization	1	LS	\$ 20,000.00	\$ 20,000.00	\$ 40,000.00	\$ 40,000.00			\$ 60,000.00
	2	Clearing and Grubbing	1	LS	\$ 5,000.00	\$ 5,000.00	\$ 15,000.00	\$ 15,000.00			\$ 20,000.00
	3	Environmental Mitigation	1	LS		\$ -		\$ -	\$ 250,000.00	\$ 250,000.00	\$ 250,000.00
	4	20' Access Path Grading and Retaining Walls	1660	LF	\$ 250.00	\$ 415,000.00	\$ 250.00	\$ 415,000.00			\$ 830,000.00
	5	Sewer Bypass	1	LS	\$ 5,000.00	\$ 5,000.00	\$ 10,000.00	\$ 10,000.00			\$ 15,000.00
	6	Existing Sewer Demolition/Abandonment	1	LS	\$ -	\$ -	\$ 5,000.00	\$ 5,000.00			\$ 5,000.00
	7	8" PVC DR26 Gravity Sewer, 4'-8' Deep Trench	1800	LF	\$ 60.00	\$ 108,000.00	\$ 60.00	\$ 108,000.00			\$ 216,000.00
	8	8" PVC DR26 Gravity Sewer, 8'-14' Deep Trench	450	LF	\$ 80.00	\$ 36,000.00	\$ 80.00	\$ 36,000.00			\$ 72,000.00
	9	Precast Polymer 48" Manhole, 4'-8' Deep	5	EA	\$ 8,500.00	\$ 42,500.00	\$ 5,000.00	\$ 25,000.00			\$ 67,500.00
	10	Precast Polymer 48" Manhole, 8'-12' Deep	3	EA	\$ 9,500.00	\$ 28,500.00	\$ 7,000.00	\$ 21,000.00			\$ 49,500.00
	11	Service Lateral (to Property Line)	19	EA	\$ 250.00	\$ 4,750.00	\$ 500.00	\$ 9,500.00			\$ 14,250.00
	12	Erosion Control	1	LS	\$ 10,000.00	\$ 10,000.00	\$ 10,000.00	\$ 10,000.00			\$ 20,000.00
	13	Post-Construction Rehabilitation	1	LS	\$ 5,000.00	\$ 5,000.00	\$ 10,000.00	\$ 10,000.00			\$ 15,000.00
	14	Traffic Control	1	LS	\$ 2,500.00	\$ 2,500.00	\$ 2,500.00	\$ 2,500.00			\$ 5,000.00
		Subtotals				\$ 682,250.00	\$ 707,000.00	\$ 250,000.00		\$ 1,639,250.00	
		Division 1 Costs	@	2.00%		\$ 13,645.00	\$ 14,140.00			\$ 27,785.00	
		Subtotals				\$ 695,895.00	\$ 707,000.00	\$ 250,000.00		\$ 1,667,035.00	
		Taxes - Materials Costs	@	9.00%		\$ 62,630.55				\$ 62,630.55	
		Subtotals				\$ 758,525.55	\$ 707,000.00	\$ 250,000.00		\$ 1,729,665.55	
		Contractor Markup for Sub	@	12.00%		\$ 91,023.07	\$ 84,840.00	\$ 30,000.00		\$ 205,863.07	
		Subtotals				\$ 758,525.55	\$ 707,000.00	\$ 250,000.00		\$ 1,935,528.62	
		Contractor OH&P	@	15.00%		\$ 113,778.83	\$ 106,050.00	\$ 37,500.00		\$ 257,328.83	
		Subtotals				\$ 872,304.38	\$ 813,050.00	\$ 287,500.00		\$ 1,972,854.38	
		Estimate Contingency	@	30.00%						\$ 591,856.31	
		Subtotals								\$ 2,564,710.70	
		Escalate to Midpoint of Construct	@	3.00%						\$ 76,941.32	
		Estimated Bid Cost								\$ 2,641,652.02	
		<b>Total Estimate</b>								<b>\$ 2,641,660.00</b>	
		<b>Total Estimate</b>								<b>\$ 2,640,000.00</b>	
		<b>Annualized Capital Cost @ i-5%, n=30</b>								<b>\$ 171,735.79</b>	

**OPINION OF PROBABLE CONSTRUCTION COST**



Project: Pescadero Road Sewer Replacement Project

Prepared By: JAD/NEP

Building, Area: Alternative B - Pescadero Road Alignment

Date Prepared: 12/31/2021

MNS Proj. No. CMAWD.210401

Estimate Type:  Conceptual  
 Preliminary (w/o plans)  Construction  
 Design Development @  Change Order  
\_\_\_\_\_ % complete

Current at ENR \_\_\_\_\_  
Escalated to ENR \_\_\_\_\_  
Months to Midpoint of Construction \_\_\_\_\_

Spec. No.	Item No.	Description	Qty.	Units	Materials		Installation		Sub-Contractor		Total
					\$/Unit	Total	\$/Unit	Total	\$/Unit	Total	
	1	Mobilization and Demobilization	1	LS	\$ 15,000.00	\$ 15,000.00	\$ 35,000.00	\$ 35,000.00			\$ 50,000.00
	2	Sewer Bypass	1	LS	\$ 2,000.00	\$ 2,000.00	\$ 3,000.00	\$ 3,000.00			\$ 5,000.00
	3	Existing Sewer Main Abandonment	1800	LF	\$ 10.00	\$ 18,000.00	\$ 5.00	\$ 9,000.00			\$ 27,000.00
	4	Existing Sewer Manhole Demolition/Abandonment	8	EA	\$ 750.00	\$ 6,000.00	\$ 750.00	\$ 6,000.00			\$ 12,000.00
	5	Existing Sewer Abandonment/Removal N601 to N603	370	LF	\$ -	\$ -	\$ 10.00	\$ 3,700.00			\$ 3,700.00
	6	10" PVC DR26 Gravity Sewer, 4'-8' Deep Trench	970	LF	\$ 80.00	\$ 77,600.00	\$ 100.00	\$ 97,000.00			\$ 174,600.00
	7	10" PVC DR26 Gravity Sewer, 8'-14' Deep Trench	700	LF	\$ 100.00	\$ 70,000.00	\$ 110.00	\$ 77,000.00			\$ 147,000.00
	8	10" PVC DR26 Gravity Sewer, 14'-24' Deep Trench	540	LF	\$ 160.00	\$ 86,400.00	\$ 400.00	\$ 216,000.00			\$ 302,400.00
	9	Precast Polymer 48" Manhole, 4'-8' Deep	6	EA	\$ 8,500.00	\$ 51,000.00	\$ 5,000.00	\$ 30,000.00			\$ 81,000.00
	10	Precast Polymer 48" Manhole, 8'-14' Deep	2	EA	\$ 9,500.00	\$ 19,000.00	\$ 7,000.00	\$ 14,000.00			\$ 33,000.00
	11	Precast Polymer 48" Manhole, 14'-18' Deep	2	EA	\$ 12,500.00	\$ 25,000.00	\$ 10,000.00	\$ 20,000.00			\$ 45,000.00
	12	Precast Polymer 48" Manhole, 20'-24' Deep	1	EA	\$ 16,000.00	\$ 16,000.00	\$ 15,000.00	\$ 15,000.00			\$ 31,000.00
	13	Service Lateral to Property Line (Gravity)	18	EA	\$ 500.00	\$ 9,000.00	\$ 1,000.00	\$ 18,000.00			\$ 27,000.00
	14	Service Lateral to Property Line (Pressurized)	19	EA	\$ 500.00	\$ 9,500.00	\$ 1,000.00	\$ 19,000.00			\$ 28,500.00
	15	Traffic Control	1	LS	\$ 7,500.00	\$ 7,500.00	\$ 15,000.00	\$ 15,000.00			\$ 22,500.00
		Subtotals				\$ 397,000.00		\$ 542,700.00	\$ -		\$ 939,700.00
		Division 1 Costs	@	2.00%		\$ 7,940.00		\$ 10,854.00			\$ 18,794.00
		Subtotals				\$ 404,940.00		\$ 553,554.00	\$ -		\$ 958,494.00
		Taxes - Materials Costs	@	9.00%		\$ 36,444.60					\$ 36,444.60
		Subtotals				\$ 441,384.60		\$ 553,554.00	\$ -		\$ 994,938.60
		Contractor Markup for Sub	@	12.00%		\$ 52,966.15		\$ 66,426.48	\$ -		\$ 119,392.63
		Subtotals				\$ 441,384.60		\$ 553,554.00	\$ -		\$ 1,114,331.23
		Contractor OH&P	@	15.00%		\$ 66,207.69		\$ 83,033.10	\$ -		\$ 149,240.79
		Subtotals				\$ 507,592.29		\$ 636,587.10	\$ -		\$ 1,144,179.39
		Estimate Contingency	@	30.00%							\$ 343,253.82
		Subtotals									\$ 1,487,433.21
		Escalate to Midpoint of Construct	@	3.00%							\$ 44,623.00
		Estimated Bid Cost									\$ 1,532,056.20
		<b>Total Estimate</b>									<b>\$ 1,532,060.00</b>
		<b>Total Estimate</b>									<b>\$ 1,530,000.00</b>
		<b>Annualized Capital Cost @ i=5%, n=30</b>									<b>\$ 99,528.70</b>



## Appendix D. Biological Alternatives Analysis





# MEMORANDUM

**Date:** February 19, 2016

**To:** Nick Panofsky, Senior Project Engineer, MNS Engineers, Inc.

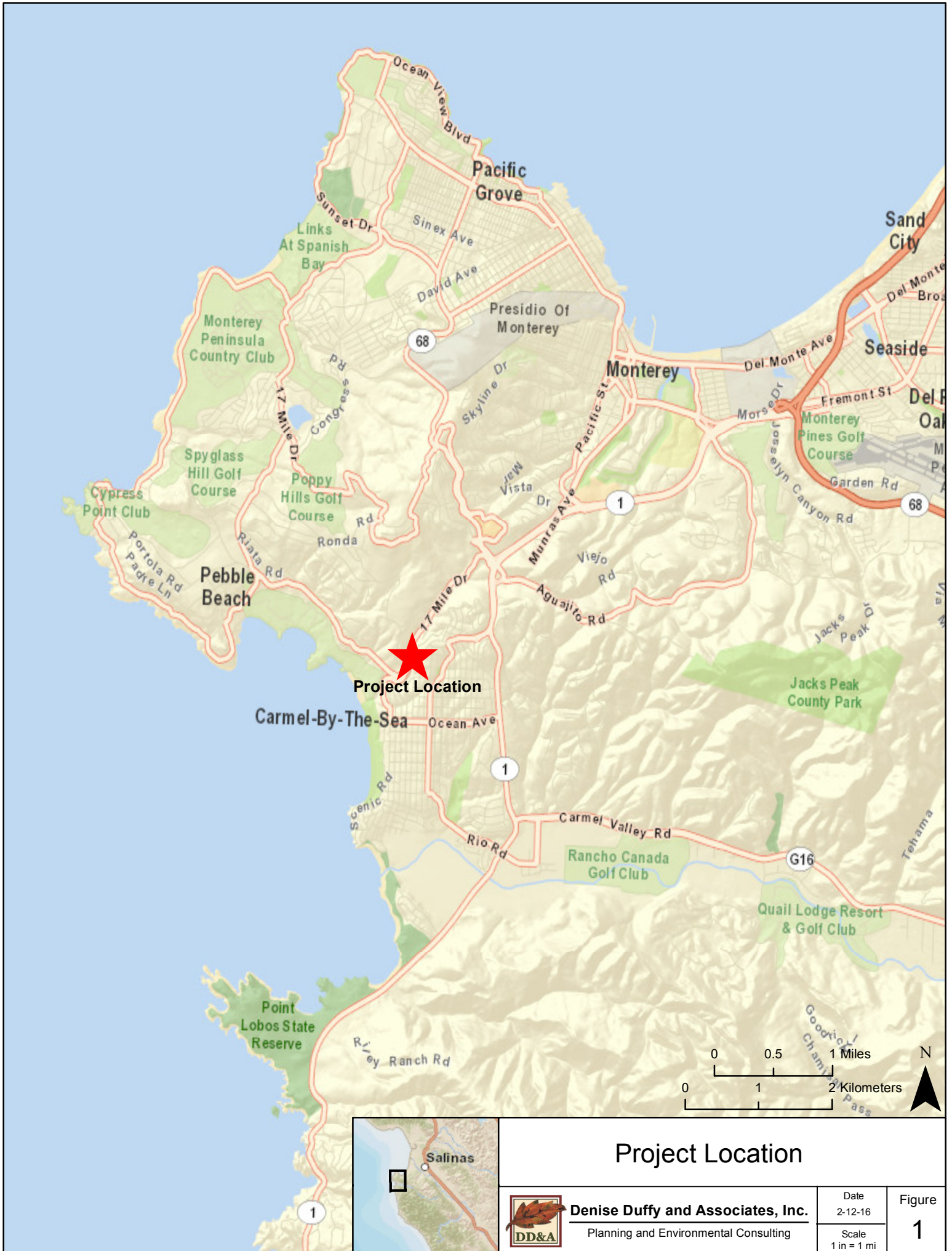
**From:** Josh Harwayne, Senior Project Manager, DD&A  
Shaelyn Davis, Assistant Environmental Scientist, DD&A

**Subject:** Biological Alternatives Analysis for the Pescadero Road Sewer Main Replacement Project

---

This Biological Alternatives Analysis provides the results of reconnaissance-level biological surveys conducted in January and February 2016 for two potential alternative alignments for the Pescadero Road Sewer Main Replacement Project (Project), and a comparison of the biological resources present at each proposed alignment. The Pescadero Road Sewer Main is part of the Carmel Area Wastewater District sewer system and serves residents along Pescadero Road and adjacent streets in Monterey County, California (Figure 1). The existing section of sewer main to be replaced begins on Pescadero Road at manhole N601, extends from Pescadero Road to the west, inside of the property line at 24652 Pescadero Road to manhole N602, then continues south in property believed to be owned by the Del Monte Forest Conservancy and designated as the Pescadero Canyon Property. From this property, the sewer main continues south, through two private properties including 2525 2nd Avenue, before entering back into the north end of Toyon Heights, a private road, to the intersection of Toyon Heights, 2nd Avenue, and Monte Verde Street. Different segments of the existing alignment occur within the Del Monte Forest and Carmel Area Land Use Plan Areas of Monterey County. The first alternative alignment (Alternative A) follows the existing alignment approximately. Alternative A would consist of replacing the existing line in-place and would include a temporary 20-foot-wide access path that would be cleared and grubbed of all vegetation, and graded to provide a drivable surface along the alignment. The second alternative alignment (Alternative B) abandons the existing section of sewer main, and would involve the construction a new sewer main within the Pescadero Road and Monte Verde Street right-of-way. Alternative B would require the demolition of the existing manholes along the current alignment of the section of sewer main, and the filling of the abandoned sewer main with slurry. Both alternatives occur within the Coastal Zone in an unincorporated area of Monterey County. The purpose of this memo is to describe the existing habitats, known or potential special-status species that may be impacted by the Project, and sensitive habitat, if present, within each site; identify any future biological surveys and regulatory permits that may be required; and provide a comparison of the biological resources present at each site and a recommendation for the biologically preferred alternative.

The surveys of the two potential alternative sites were completed by Denise Duffy and Associates, Inc. (DD&A) Senior Environmental Scientist Josh Harwayne, and DD&A Assistant Environmental Scientist Shaelyn Hession, on January 28 and February 11, 2016. Survey methods included walking the two proposed alignments and using aerial maps to identify general habitat types and potential sensitive habitats, and conducting a focused survey of appropriate habitat for special-status plant species. Concurrently, a reconnaissance-level wildlife habitat and special-status species survey was conducted to identify suitable habitat and any special-status wildlife species observed.



## Project Location



**Denise Duffy and Associates, Inc.**  
 Planning and Environmental Consulting

Date  
2-12-16  
 Scale  
1 in = 1 mi

Figure  
**1**

## Biological Survey Results

### Habitat Types

#### Alternative A

Alternative A approximately follows the existing alignment through the Pescadero Canyon Property on steep unstable slopes, within degraded Monterey pine (*Pinus radiata*) forest adjacent to, but above, the Pacheco Creek Riparian corridor. Dominant plant species within the tree stratum in the degraded Monterey Pine forest included Monterey pine and coast live oak (*Quercus agrifolia*). The dominant species in the understory present along the alignment included non-native grass species, horticultural species that likely escaped from adjacent properties, cape ivy (*Delairea odorata*), Bermuda buttercup (*Oxalis per-caprae*), hedge-nettle (*Stachys sp.*) and Poison Oak (*Toxicodendron diversilobum*). Approximately 0.9 acres of Monterey pine forest would be temporarily impacted as part of the Project if Alignment A is selected. Portions of the existing alignment and the Alternative A alignment are located in the Del Monte Forest Land Use Plan Area and Carmel Area Land Use Plan Area (Figure 2).

Monterey pine forest (*Pinus radiata* – *Quercus agrifolia*/ *Toxicodendron diversilobum* Association) is listed as sensitive on the California Department of Fish and Wildlife's (CDFW) Natural Communities List, (CDFG, 2010). This habitat type is also an environmentally sensitive habitat area (ESHA) under the California Coastal Act. Development is restricted within the coastal zone and prohibited within designated ESHA, unless the development is coastal dependent and does not have a significant effect on the resources. Furthermore this habitat is identified as sensitive in the Del Monte Forest and Carmel Area Land Use Plans. Tree removal from forest ESHA is prohibited within the Del Monte Forest Land Use Plan Area unless it is part of restoration and enhancement efforts. Impacts to Monterey pine forest associated with the Alternative A alignment would need to be addressed and mitigated in compliance with CEQA Guidelines and local Land Use Plans. A Coastal Development Permit would be required as the project is within the Coastal Zone and is not covered under any exemptions to CEQA or Coastal Permit requirement.






The Del Monte Forest and Carmel Area Land Use Plans may restrict or prohibit the removal of trees, grading, and excavation along the Alternative A alignment. If the removal of native trees associated with Alternative A alignment is permitted by the local Land Use Plans, the preparation of a Forest Management Plan per Section 20.146.060.B of the Carmel Land Use Plan and Implementation Plan may be required. Additional habitat surveys utilizing GPS would be required to provide an estimate of the number and size of native trees to be removed, as well as a more accurate estimate of acres to be impacted by the construction of the access corridor.

Two areas that may qualify as potential coastal wetlands exist adjacent to and just north of manhole N607. These areas would be impacted as part of the Project with the Alternative A alignment and would require a coastal development permit; however, a coastal development permit would be required for other aspects of the Project with the Alternative A alignment including grading of the temporary access road. A wetland delineation would be required to determine total area of potential coastal wetlands within the Alternative A alignment. Additionally, the steep unstable slopes and presence of Pacheco Creek below the Alternative A alignment would require that care is taken and provisions set in place, especially when grading the access road, to prevent impacts to the creek and associated riparian area. No construction will occur within the creek or the associated riparian area.

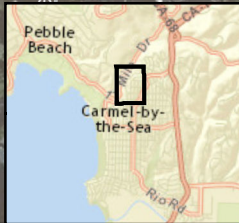
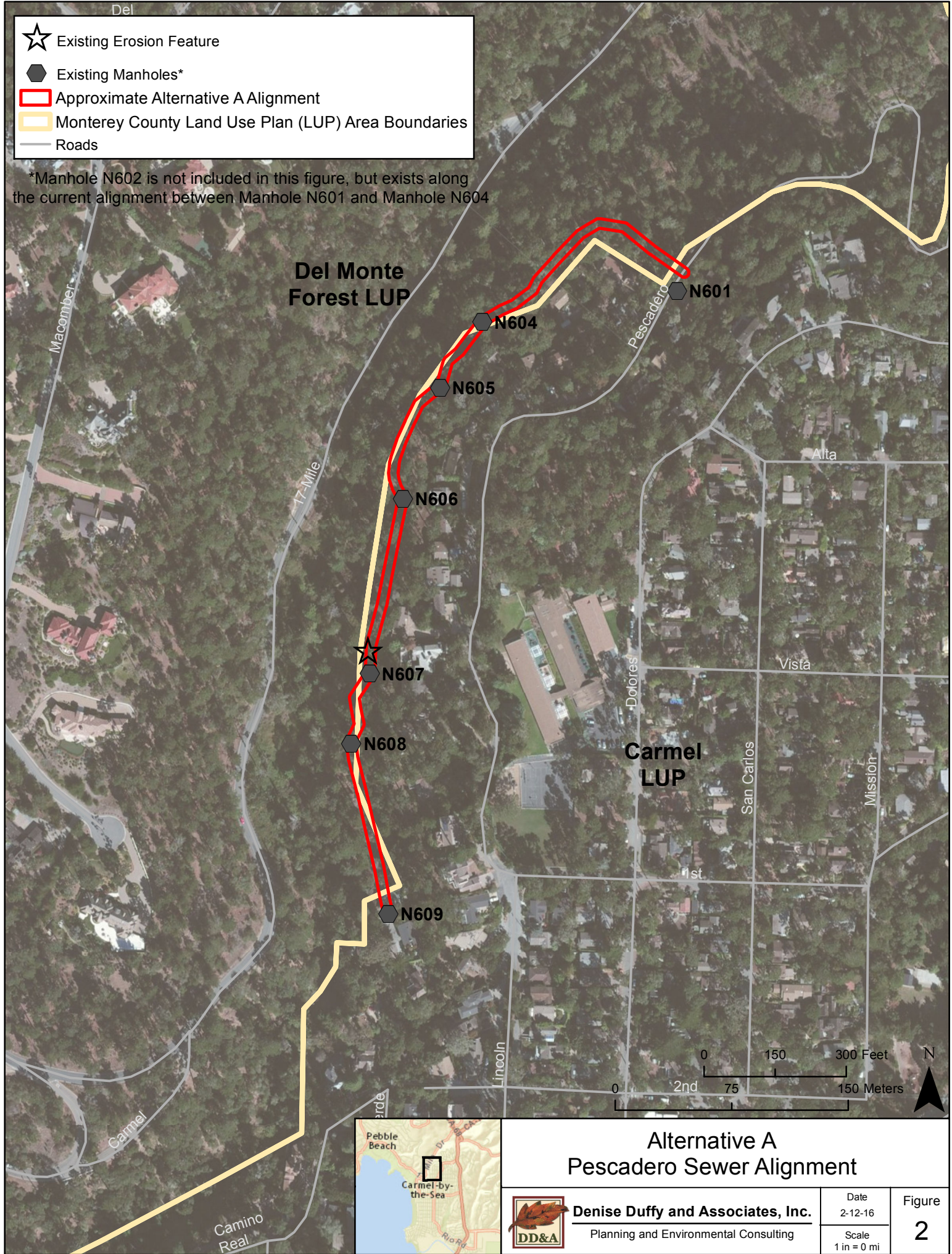
#### Alternative B

With Alternative B a new section of sewer main would be constructed within the Pescadero Road and Monte Verde Street right-of-way. The new sewer main would connect existing manhole N601 to existing manhole N610. Construction activities for the new sewer main along the Alternative B alignment would occur entirely in developed habitat consisting of paved streets. One section of the Alternative B alignment



-  Existing Erosion Feature
-  Existing Manholes\*
-  Approximate Alternative A Alignment
-  Monterey County Land Use Plan (LUP) Area Boundaries
-  Roads

\*Manhole N602 is not included in this figure, but exists along the current alignment between Manhole N601 and Manhole N604



## Alternative A Pescadero Sewer Alignment



**Denise Duffy and Associates, Inc.**  
Planning and Environmental Consulting

Date  
2-12-16  
Scale  
1 in = 0 mi

Figure  
**2**



would cross a landscaped hillside. This section would be constructed using horizontal directional drilling (HDD), to avoid disturbing the landscaped hillside. The remainder of the new sewer would be constructed using open trench construction. No impacts associated with the construction of the new sewer main with Alternative B would occur outside of paved areas.

Alternative B would be exempt from Coastal Development Permit requirements and from CEQA requirements as this alternative falls under the following statutory exemptions:

- According to Title 20, Zoning Ordinance for the County of Monterey, Chapter 20.70.120(G), Exemptions from Coastal Development Permits, Alternative B would be considered exempt from coastal permit requirements. As stated in the ordinance: The installation, testing, and placement in service or the replacement of any necessary utility connection between an existing service facility and any development provided that the County may, where necessary, require reasonable conditions to mitigate any adverse impacts on coastal resources, including scenic resources. (See Coastal Commission's September 5, 1978 "Repair, Maintenance and Utility Hook-Up Exclusions from Permit Requirements" document for further detail on which public utility projects are exempt). Under this guidance from the Coastal Commission, for excluded activities related to transmission, distribution, and communication facilities, a coastal permit is not required to install, test, place in service, maintain, replace, modify, or relocate underground facilities provided that the work is limited to public road or railroad rights-of-way or public utility easements and provided that there is no removal of major vegetation and the site is restored as close as reasonably possible to its original condition.
- Alternative B would be exempt from CEQA under Section 15282(k), which identifies a statutory exemption for: *the installation, of new pipeline or maintenance, repair, restoration, removal, or demolition of an existing pipeline as set forth in Section 21080.21 of the Public Resources Code, as long as the project does not exceed one mile in length.*
- Alternative B would be exempt from CEQA under Public Resources Code 21080.21 states: *This division does not apply to any project of less than one mile in length within a public street or highway or any other public right-of-way for the installation of a new pipeline or the maintenance, repair, restoration, reconditioning, relocation, replacement, removal, or demolition of an existing pipeline.*
- Alternative B would also be exempt from CEQA under Section 15301, which identifies a categorical exemption for: *operation, repair, maintenance, permitting, leasing, licensing, or minor alteration of existing public or private structures, facilities, mechanical equipment, or topographical features, involving negligible or no expansion beyond that existing at the time of the lead agency's determination...Examples include, but are not limited to:...(b) existing facilities of both investor and publicly-owned utilities used to provide electric power, natural gas, sewerage, or other public utility services..."*

If a coastal permit is not required, a Coastal Exemption is issued by the County. The Coastal Exemption is proof that review and a decision have been rendered by authorized staff. Alternative B will require issuance of a Coastal Exemption from the County.

The existing sewer main is located within degraded Monterey pine forest, as described above. In addition to the construction of the new sewer, the existing sewer would need to be properly abandoned under Alternative B. Removal of the manholes and filling of the abandoned sewer main with slurry would be completed using hand and power tools carried on foot from Pescadero Road. Hoses and cords from Pescadero Road would be required to convey slurry and power equipment would need to be laid on grade to accomplish this work. Provisions would be set in place to prevent any slurry or other materials from

spilling from the sewer main and manholes to the surrounding areas. No permanent or ground disturbing impacts would occur within the Monterey pine forest as a result of abandoning the existing sewer main. Additionally, impacts to the area that may qualify as potential coastal wetlands exist adjacent to manhole N607 would likely be less-than-significant.

## Special-Status Species

A special-status species table, included as Attachment A, discusses the presence and/or potential presence of special-status species within the current alignment of the sewer main. Each of these species' known or with a moderate or high potential presence within the alternative alignments is discussed below, along with typical avoidance, minimization, and mitigation measures to reduce impacts to each species.

### Wildlife

The following table includes wildlife species known or with a moderate or high potential presence within the alternative alignments:

Species	Status <sup>1</sup>	Alternative A	Alternative B
<b>Invertebrates</b>			
Monarch butterfly ( <i>Danaus plexippus</i> )	CNDDB	Potential	Potential (along the existing sewer main alignment)
<b>Mammals</b>			
Monterey dusky-footed woodrat ( <i>Neotoma macrotis luciana</i> )	CSC	Potential	Potential (along the existing sewer main alignment)
<b>Birds</b>			
Nesting Raptors & Other Protected Avian Species	MBTA, DFG Code	Potential	Potential

### *Monarch Butterfly*

The Monterey pine forest, in which the existing section of sewer main is located, may be suitable monarch butterfly habitat. Monarch Butterflies are included on the CDFW's CNDDB "Special Animals" list. No permits are required for impacts these species; however, management considerations consistent with CDFW recommendations are typically included under CEQA. These mitigation measures would likely be required for Alternative A. No habitat disturbance will occur within the Monterey pine forest as a result of Alternative B. Standard measures that are typically recommended to reduce impacts to sensitive habitat include:

- To avoid and reduce impacts to the monarch butterfly, the project applicant will retain a qualified biologist to review the project for potential to impact monarch butterflies prior to completion of the final design. If known or potential winter roost sites will be impacted, the biologist shall make recommendations to avoid impacts including, but not limited to, relocation/redesign of project features to avoid roost sites, guidance regarding tree removal and trimming at roost sites, and recommendations regarding planting additional roost trees. Construction shall not occur within 100 feet of known or potential roost sites between November 1 and May 1 as feasible. If

<sup>1</sup> FE: Federally Endangered; ST: State Threatened; CSC: California Species of Special Concern; CFP: California Fully Protected; CNDDB: species on the CDFW's "Special Animals" list; MBTA: Protected under the Migratory Bird Treaty Act (MBTA); DFG Code: Protected under California Department of Fish and Game Code (CDFG Code).



construction must occur during this period, the qualified biologist shall survey known and potential roost sites to confirm occupancy by monarch butterflies prior to start of construction within 100 feet. Multiple surveys may be necessary and the closest known roost sites shall be used as voucher sites to confirm the timing of butterfly arrival. If monarch butterflies are determined to be absent from a roost site, construction may commence. If monarch butterflies are found at a roost site, construction shall not occur within 100 feet of the roost site until the biologist has determined that the butterflies have left the area. The biologist shall visit the voucher sites to confirm that butterflies have left the region.

#### *Monterey Dusky-Footed Woodrat*

Monterey dusky-footed woodrats have the potential to be present within the Monterey pine forest habitat where work would be conducted as part of both alternatives. This species is designated as a California species of special concern by the CDFW. No permits are required for impacts to this species; however, management considerations consistent with CDFW recommendations are typically included under CEQA. Mitigation measures would likely be required for Alternative A. No ground or habitat disturbance will occur within the Monterey pine forest as a result of Alternative B. Standard measures that are typically recommended to reduce impacts to Monterey dusky-footed woodrat include:

- To avoid and reduce impacts to the Monterey dusky-footed woodrat, the project applicant will retain a qualified biologist to conduct pre-construction surveys in suitable habitat proposed for construction, ground disturbance, or staging within three days prior to construction for woodrat nests within the project area and in a buffer zone 100 feet out from the limit of disturbance. All woodrat nests will be flagged for avoidance of direct construction impacts, where feasible. All nests within 25 feet of the project site will be avoided and protected during project activities. Nests that cannot be avoided will be manually deconstructed prior to land clearing activities to allow animals to escape harm. If a litter of young is found or suspected, nest material will be replaced, and the nest left alone for 2-3 weeks before a re-check to verify that young are capable of independent survival before proceeding with nest dismantling.

#### *Nesting Raptors and Other Protected Avian Species*

Large trees within the alignment of both Alternative A and Alternative B may provide nesting habitat avian species protected under the Migratory Bird Treaty Act (MBTA) and CDFG Code. No permits are required for potential impacts to avian species protected under the MBTA and CDFG Code; however, management considerations consistent with CDFW recommendations are typically included under CEQA. Mitigation measures would likely be required for Alternative A and avoidance measures could be implemented for Alternative B. Measures that are typically recommended to reduce impacts to nesting raptors and other protected avian species include:

- Timing construction activities that may directly (e.g., vegetation removal) or indirectly (e.g., noise/ground disturbance) affect protected nesting avian species to avoid the breeding and nesting season. Specifically, vegetation and/or tree removal can be scheduled after September 16 and before January 31.
- Alternatively, a qualified biologist will be retained by the project applicant to conduct pre-construction surveys for nesting raptors and other protected avian species within 500 feet of proposed construction activities if construction occurs between February 1 and September 15. Surveys for nesting birds may be required to continue during construction to address new arrivals, and because some species breed multiple times in a season. The necessity and timing of these continued surveys will be determined by the qualified biologist based on review of the final construction plans and in coordination with the United States Fish and Wildlife Service (USFWS) and CDFW, as needed.

- If raptors or other protected avian species nests are identified during the pre-construction surveys, the qualified biologist will notify the project applicant and an appropriate no-disturbance buffer will be imposed within which no construction activities or disturbance should take place (generally 500 feet in all directions for raptors; other avian species may have species-specific requirements) until the young of the year have fledged and are no longer reliant upon the nest or parental care for survival, as determined by a qualified biologist

Plants

The following table includes plant species known or with a moderate or high potential presence within the alternative alignments:

Species	Status <sup>2</sup>	Alternative A	Alternative B
Hickman’s onion ( <i>Allium hickmanii</i> )	List 1B	Potential	Potential (along the existing sewer main alignment)
Hooker’s manzanita ( <i>Arctostaphylos hookeri</i> ssp. <i>hookeri</i> )	List 1B	Potential	Potential (along the existing sewer main alignment)
Monterey pine ( <i>Pinus radiata</i> )	List 1B	Present	Present (along the existing sewer main alignment)
Yadon’s rein orchid ( <i>Piperia yadonii</i> )	FE/ List 1B	Potential	Potential (along the existing sewer main alignment)
Pine rose ( <i>Rosa pinetorum</i> )	List 1B	Potential	Potential (along the existing sewer main alignment)

*Alternative A*

Monterey pine is present along the existing and proposed alignment for Alternative A. The creation of a 20-foot-wide access path would require the removal of native trees, likely including Monterey pine. No permits are required for impacts these species; however, however, management considerations consistent with CDFW recommendations and local Land Use Plans are typically included under CEQA. As stated above, tree removal from forest ESHA is prohibited within the Del Monte Forest Land Use Plan Area unless it is part of restoration and enhancement efforts. If a Forest Management Plan is prepared as mitigation for impacts to Monterey Pine Forest, removal of individual Monterey pine trees would be included in the Forest Management Plan. The Forest Management Plan would need to include planting of Monterey pine trees at a 3:1 ratio.

Other special-status plant species with the potential to be present along the existing and proposed alignment for Alternative A include Hickman’s onion, Hooker’s manzanita, Yadon’s rein orchid, and pine rose. These plants are listed in the California Native Plant Society (CNPS) California Rare Plant Ranks (CRPR, formerly known as CNPS Lists) as 1B and are also treated as special-status species under CEQA. In addition to being a list 1B species, Yadon’s rein orchid is also a federally listed species under the Endangered Species Act. Standard measures that are typically recommended to reduce impacts to these species include:

- Individuals shall be avoided to the maximum extent possible.
- If avoidance is not feasible, species shall be replaced at a 3:1 ratio for the number of individuals impacted and a Rare Plant Restoration Plan shall be prepared by a qualified biologist in

---

<sup>2</sup> FE: Federally Endangered; List 1B: California Native Plant Society List 1B Species (rare, threatened, or endangered in California and elsewhere).

coordination with CDFW and the project applicant, and implemented. The plan shall include, but is not limited to, the following:

- a description of the baseline conditions of the habitats within the area of impact, including the presence of any special-status species, their locations, and densities;
- procedures to control non-native species invasion and elimination of existing non-native species within the area of impact;
- provisions to ensure compliance with the requirements of the plan;
- a detailed description of on-site and off-site restoration areas, salvage of seed and/or soil bank, plant salvage, seeding and planting specifications, including, if appropriate, increased planting ratio to ensure the 3:1 success ratio; and
- a monitoring program that describes annual monitoring efforts which incorporate success criteria and contingency plans if success criteria are not met.

#### *Alternative B*

No impacts to special-status plant species would occur as a result of the construction of the new sewer main with Alternative B as no construction would occur outside of paved areas. Activities associated with the abandonment of the existing sewer main segment would not have an impact on special-status plants as no ground disturbance would occur within the Monterey pine forest.

### **Conclusions**

#### Alternative A

Alternative A would include impacts to approximately 0.9 acres of degraded Monterey pine forest. Monterey Pine Forest is a sensitive habitat as listed on the CNDDDB's working list of high priority and rare natural communities, is ESHA, and is identified as a sensitive habitat in the applicable Land Use Plans. The Del Monte Forest and Carmel Area Land Use Plans may restrict or prohibit the removal of trees, grading, and excavation along the Alternative A alignment. Additionally, two areas that may be potential coastal wetlands would be impacted along this alignment. As with Alternative B, a wetland delineation would be required to determine the size and location of these resources. This sensitive habitat has the potential to support special-status plant species. A focused survey during the appropriate blooming period for each species would be necessary to identify the presence or absence of each of these species. Monterey pine forest within Alignment A may potentially support Yadon's rein orchid, a federally endangered species. If special-status plant species are identified within the site and cannot be avoided, mitigation for these species may be required. Impacts to special-status wildlife species known or with the potential to occur along the Alternative A alignment can likely be mitigated through standard pre-construction and avoidance measures. A Coastal Development Permit is required as this project would occur in the Coastal Zone. An Initial Study / Mitigated negative Declaration would be required under CEQA.

#### Alternative B

The Alternative B alignment would not impact the Monterey pine forest and impacts to potential coastal wetlands along the existing alignment under this alternative would be less-than-significant. Construction activities for Alternative B would occur only in developed areas, therefore, no impacts to special-status plant species will occur. Potential impacts to nesting raptors and other protected avian species could be avoided by timing construction to occur outside of the breeding season (typically after September 16 and before January 31) or conduct surveys to identify presence and avoid impacts. This alternative would be exempt from Coastal Permit and CEQA requirements.

## Recommendations

The following table provides a brief outline of the positive and potentially negative aspects of each alternative, the potential impacts, CEQA documentation likely required, typical mitigation that would likely be required, and the permits that will likely be required for each alternative:

<b>Alternative</b>	<b>Potential Impacts</b>	<b>Potential Mitigation</b>	<b>CEQA Documentation</b>	<b>Regulatory Permits</b>
<b>A</b>	<ul style="list-style-type: none"> <li>▪ Potential Coastal Wetlands (no federal wetland)</li> <li>▪ Monarch Butterfly</li> <li>▪ Monterey Dusky-Footed Woodrat</li> <li>▪ Nesting Raptors and other Protected Avian Species</li> <li>▪ Special-Status Plant Species</li> <li>▪ Monterey Pine Forest Sensitive Habitat/ESHA</li> <li>▪ Native Tree Species</li> </ul>	<ul style="list-style-type: none"> <li>▪ Coastal Wetlands Restoration</li> <li>▪ Monarch Butterfly Surveys and Avoidance</li> <li>▪ Monterey Dusky-Footed Woodrat Surveys, Avoidance, or Deconstruction of Nests</li> <li>▪ Nesting Raptors and Other Protected Avian Species Surveys, and Avoidance</li> <li>▪ Special-Status Plant Surveys, Avoidance, or Restoration</li> <li>▪ Monterey Pine Forest, Surveys, Avoidance, or Restoration</li> <li>▪ Preparation of a Forest Management Plan</li> </ul>	<ul style="list-style-type: none"> <li>▪ Initial Study/Mitigated Negative Declaration</li> </ul>	<ul style="list-style-type: none"> <li>▪ Coastal Development Permit</li> </ul>
<b>B</b>	<ul style="list-style-type: none"> <li>▪ Coastal Wetlands (Less-than-significant)</li> <li>▪ Nesting Raptors and other Protected Avian Species (Avoidance via Timing Construction to occur Outside of Breeding Season or Surveys)</li> </ul>	<ul style="list-style-type: none"> <li>▪ None</li> </ul>	<ul style="list-style-type: none"> <li>▪ Exempt</li> </ul>	<ul style="list-style-type: none"> <li>▪ Exempt</li> </ul>

Based on the information above, Alternative B would be the biological preferred alignment, as no ground disturbance outside of developed areas or impacts to Monterey pine forest would occur.

**Cost and Schedule Estimates**

<b>Alternative</b>	<b>Environmental Documentation/Permit</b>	<b>Cost Estimate</b>	<b>Schedule Estimate</b>
<b>A</b>	Initial Study/ Mitigated Negative Declaration	\$19,500	90 to 120 days from receiving 60% plans and a complete project description
<b>A</b>	Coastal Development Permit	\$6,500	30 to 60 days from project approval
<b>B</b>	Notice of Exemption	\$564	File with County clerk within 5 days of project approval – 35 day posting period
<b>B</b>	Coastal Exemption	\$1,128	Submit materials to the County upon project approval- Schedule is dependent on the County's response

If you have any questions or comments regarding this memorandum, please feel free to contact Josh Harwayne or Shaelyn Hession at (831) 373-4341.

**ATTACHMENT A – SPECIAL-STATUS SPECIES TABLE**

## Special Status Species Table

Species	Status (Service/ Department/CNPS)	General Habitat	Potential Occurrence within Project Vicinity
<b>MAMMALS</b>			
<i>Corynorhinus townsendii</i> Townsend's big-eared bat	-- / CSC / --	Found primarily in rural settings from inland deserts to coastal redwoods, oak woodland of the inner Coast Ranges and Sierra foothills, and low to mid-elevation mixed coniferous-deciduous forests. Typically roost during the day in limestone caves, lava tubes, and mines, but can roost in buildings that offer suitable conditions. Night roosts are in more open settings and include bridges, rock crevices, and trees.	<b>Low</b> Nearest CNDDDB occurrence is a historic occurrence from 1947 and is approximately 5 miles from the project study area.
<i>Lasiurus cinereus</i> Hoary bat	-- / CNDDDB / --	Prefers open habitats or habitat mosaics with access to trees for cover and open areas or edge for feeding. Generally roost in dense foliage of trees; does not use buildings for roosting. Winters in California and Mexico and often migrates towards summer quarters in the north and east during the spring. Young are born and reared in summer grounds, which is unlikely to occur in California.	<b>Low</b> Nearest CNDDDB occurrence is a historic occurrence from 1907 and is approximately 1.5 miles from the project study area
<i>Neotoma macrotis luciana</i> Monterey dusky-footed woodrat	-- / CSC / --	Forest and oak woodland habitats of moderate canopy with moderate to dense understory. Also occurs in chaparral habitats.	<b>Moderate</b> Habitat is present within the project study site. No CNDDDB occurrences identified in the quads searched; however this species are known to occur throughout the region
<i>Reithrodontomys megalotis distichlis</i> Salinas harvest mouse	-- / CNDDDB / --	Known only to occur from the Monterey Bay region. Occurs in fresh and brackish water wetlands and probably in the adjacent uplands around the mouth of the Salinas River.	<b>Low</b> Nearest CNDDDB occurrence is a historic occurrence from 1936 and is approximately 5 miles from the project study area.
<i>Taxidea taxus</i> American badger	-- / CSC / --	Dry, open grasslands, fields, pastures savannas, and mountain meadows near timberline are preferred. The principal requirements seem to be sufficient food, friable soils, and relatively open, uncultivated grounds.	<b>Unlikely</b> No habitat is present within the project study area.

Species	Status (Service/ Department/CNPS)	General Habitat	Potential Occurrence within Project Vicinity
<b>BIRDS</b>			
<i>Agelaius tricolor</i> Tricolored blackbird (nesting colony)	-- / CSC / --	Nest in colonies in dense riparian vegetation, along rivers, lagoons, lakes, and ponds. Forages over grassland or aquatic habitats.	<b>Unlikely</b> No nesting habitat is present within the project study area
<i>Athene cunicularia</i> Burrowing owl (burrow sites & some wintering sites)	-- / CSC / --	Year round resident of open, dry grassland and desert habitats, and in grass, forb and open shrub stages of pinyon-juniper and ponderosa pine habitats. Frequent open grasslands and shrublands with perches and burrows. Use rodent burrows (often California ground squirrel) for roosting and nesting cover. Pipes, culverts, and nest boxes may be substituted for burrows in areas where burrows are not available.	<b>Unlikely</b> No habitat is present within the project study area.
<i>Buteo regalis</i> Ferruginous hawk (wintering)	-- / WL / --	An uncommon winter resident and migrant at lower elevations and open grasslands in the Modoc Plateau, Central Valley, and Coast Ranges and a fairly common winter resident of grassland and agricultural areas in southwestern California. Frequent open grasslands, sagebrush flats, desert scrub, low foothills surrounding valleys, and fringes of pinyon-juniper habitats. Does not breed in California.	<b>Unlikely</b> No habitat is present within the project study area
<i>Charadrius alexandrinus nivosus</i> Western snowy plover (nesting)	FT / CSC / --	Sandy beaches on marine and estuarine shores, also salt pond levees and the shores of large alkali lakes. Requires sandy, gravelly or friable soil substrate for nesting.	<b>Unlikely</b> No nesting habitat is present within the project study area.
<i>Cypseloides niger</i> Black swift (nesting)	-- / CSC / --	Regularly nests in moist crevice or cave on sea cliffs above the surf, or on cliffs behind, or adjacent to, waterfalls in deep canyons. Forages widely over many habitats.	<b>Unlikely</b> No nesting habitat is present within the project study area.
<i>Eremophila alpestris actia</i> California horned lark	-- / CNDDDB / --	Variety of open habitats, usually where large trees and/or shrubs are absent. Found from grasslands along the coast to deserts at sea-level and alpine dwarf-shrub habitats are higher elevations. Builds open cup-like nests on the ground.	<b>Unlikely</b> No habitat is present within the project study area.



<b>Species</b>	<b>Status (Service/ Department/CNPS)</b>	<b>General Habitat</b>	<b>Potential Occurrence within Project Vicinity</b>
<i>Oceanodroma homochroa</i> Ashy storm-petrel (nesting colony)	-- / CSC / --	Tied to land only to nest, otherwise remains over open sea. Nests in natural cavities, sea caves, or rock crevices on offshore islands and prominent peninsulas of the mainland.	<b>Unlikely</b> No nesting habitat is present within the project study area.
<i>Pelecanus occidentalis californicus</i> California brown pelican (nesting colony & communal roosts)	-- / CFP / --	Found in estuarine, marine subtidal, and marine pelagic waters along the California coast. Usually rests on water or inaccessible rocks, but also uses mudflats, sandy beaches, wharfs, and jetties.	<b>Unlikely</b> No habitat is present within the project study area.
<i>Riparia riparia</i> Bank swallow (nesting)	-- / ST / --	Nest colonially in sand banks. Found near water; fields, marshes, streams, and lakes.	<b>Unlikely</b> No nesting habitat is present within the project study area.
<b>REPTILES AND AMPHIBIANS</b>			
<i>Ambystoma californiense</i> California tiger salamander	FT / ST / --	Annual grassland and grassy understory of valley-foothill hardwood habitats in central and northern California. Need underground refuges and vernal pools or other seasonal water sources.	<b>Unlikely</b> No habitat is present within the project study area.
<i>Anniella pulchra</i> California legless lizard  (includes <i>A. p. nigra</i> and <i>A. p. pulchra</i> as recognized by the Department)	-- / CSC / --	Requires moist, warm habitats with loose soil for burrowing and prostrate plant cover, often forages in leaf litter at plant bases; may be found on beaches, sandy washes, and in woodland, chaparral, and riparian areas.	<b>Low</b> Poor quality habitat is present within the project study area. There are a number of general occurrences associated with the quad where the project study site is located.
<i>Emys marmorata</i> Western pond turtle  (includes <i>E. m. pallida</i> and <i>E. m. marmorata</i> as recognized by the Department)	-- / CSC / --	Associated with permanent or nearly permanent water in a wide variety of habitats including streams, lakes, ponds, irrigation ditches, etc. Require basking sites such as partially submerged logs, rocks, mats of vegetation, or open banks.	<b>Unlikely</b> No habitat is present within the project study area.
<i>Phrynosoma blainvillii</i> Coast horned lizard	-- / CSC / --	Associated with open patches of sandy soils in washes, chaparral, scrub, and grasslands.	<b>Unlikely</b> No habitat is present within the project study area.

Species	Status (Service/ Department/CNPS)	General Habitat	Potential Occurrence within Project Vicinity
<i>Rana draytonii</i> California red-legged frog	FT / CSC / --	Lowlands and foothills in or near permanent or late-season sources of deep water with dense, shrubby, or emergent riparian vegetation. During late summer or fall adults are known to utilize a variety of upland habitats with leaf litter or mammal burrows.	<b>Low</b> No CNDDDB records associated with Pescadero Canyon. The nearest CNDDDB occurrence is approximately 1.5 miles away in the Lower Carmel Watershed. No riparian habitat is present within the project study area.
<b>FISH</b>			
<i>Eucyclogobius newberryi</i> Tidewater goby	FE / CSC / --	Brackish water habitats, found in shallow lagoons and lower stream reaches. Tidewater gobies appear to be naturally absent (now and historically) from three large stretches of coastline where lagoons or estuaries are absent and steep topography or swift currents may prevent tidewater gobies from dispersing between adjacent localities. The southernmost large, natural gap occurs between the Salinas River in Monterey County and Arroyo del Oso in San Luis Obispo County.	<b>Unlikely</b> No habitat is present within the project study area.
<i>Oncorhynchus mykiss irideus</i> Steelhead (south/central California coast DPS)	FT / -- / --	Cold headwaters, creeks, and small to large rivers and lakes; anadromous in coastal streams.	<b>Unlikely</b> No habitat is present within the project study area.
<b>INVERTEBRATES</b>			
<i>Bombus caliginosus</i> Obscure bumble bee	-- / CNDDDB / --	Native to the West Coast of the United States. Occurs primarily along the coast in grassy prairies and meadows within the Coast Range. This species can nest both under and above ground. When nesting above ground the species may utilize abandoned bird nests. Found in areas that are relatively humid including areas that are frequently foggy.	<b>Low</b> Poor quality habitat present within the project study site. The project study area is included in a historic CNDDDB occurrence from 1925. Two additional historic occurrences from 1945 and 1955 are approximately 3 miles and 2.2 miles, respectively, from the project study area.

Species	Status (Service/ Department/CNPS)	General Habitat	Potential Occurrence within Project Vicinity
<i>Bombus occidentalis</i> Western bumble bee	-- / CNDDDB / --	Occurs in open grassy areas, urban parks, urban gardens, chaparral, and meadows. This species generally nest underground.	<b>Low</b> Poor quality habitat present within the project study site. The project study area is included in a historic CNDDDB occurrence from 1972. Two additional historic occurrences from 1938 and 1935 are approximately 1.5 miles and 4.4 miles, respectively, from the project study area.
<i>Coelus globosus</i> Globose dune beetle	-- / CNDDDB / --	Coastal dunes. These beetles are primarily subterranean, tunneling through sand underneath dune vegetation.	<b>Unlikely</b> No habitat is present within the project study area.
<i>Danaus plexippus</i> Monarch butterfly	-- / CNDDDB / --	Overwinters in coastal California using colonial roosts generally found in Eucalyptus, pine and acacia trees. Overwintering habitat for this species within the Coastal Zone represents ESHA. Local ordinances often protect this species as well.	<b>Moderate</b> Suitable habitat is present within the project study area. The nearest CNDDDB occurrence is approximately 0.8 miles from the project study area.
<i>Euphilotes enoptes smithi</i> Smith's blue butterfly	FE / -- / --	Most commonly associated with coastal dunes and coastal sage scrub plant communities in Monterey and Santa Cruz Counties. Plant hosts are <i>Eriogonum latifolium</i> and <i>E. parvifolium</i> .	<b>Unlikely</b> No habitat is present within the project study area.
<i>Lindieriella occidentalis</i> California lindieriella (fairy shrimp)	-- / CNDDDB / --	Ephemeral ponds with no flow. Generally associated with hardpans.	<b>Unlikely</b> No habitat is present within the project study area.
<b>PLANTS</b>			
<i>Allium hickmanii</i> Hickman's onion	-- / -- / 1B	Closed-cone coniferous forests, maritime chaparral, coastal prairie, coastal scrub, and valley and foothill grasslands at elevations of 5-200 meters. Bulbiferous perennial herb in the Alliaceae family; blooms March-May.	<b>Moderate</b> Marginal habitat is present within the project site. The nearest CNDDDB occurrence is approximately 0.2 miles from the project study area.
<i>Arctostaphylos edmundsii</i> Little Sur manzanita	-- / -- / 1B	Coastal bluff scrub and chaparral on sandy soils at elevations of 30-105 meters. Evergreen shrub in the Ericaceae family; blooms November-April.	<b>Unlikely</b> No habitat is present within the project study area.

Species	Status (Service/ Department/CNPS)	General Habitat	Potential Occurrence within Project Vicinity
<i>Arctostaphylos hookeri</i> ssp. <i>hookeri</i> Hooker's manzanita	-- / -- / 1B	Closed-cone coniferous forest, chaparral, cismontane woodland, and coastal scrub on sandy soils at elevations of 85-536 meters. Evergreen shrub in the Ericaceae family; blooms January-June.	<b>Moderate</b> The project study area is included in a historic CNDDDB occurrence from 1956. Additional occurrences, most historic, exist in the vicinity of the project area. The most modern occurrence in the vicinity of the project area is from 2005 and is approximately 2.7 miles away.
<i>Arctostaphylos montereyensis</i> Toro manzanita	-- / -- / 1B	Maritime chaparral, cismontane woodland, and coastal scrub on sandy soils at elevations of 30-730 meters. Evergreen shrub in the Ericaceae family; blooms February-March.	<b>Unlikely</b> No habitat is present within the project study area.
<i>Arctostaphylos pajaroensis</i> Pajaro manzanita	-- / -- / 1B	Chaparral on sandy soils at elevations of 30-760 meters. Evergreen shrub in the Ericaceae family; blooms December-March.	<b>Unlikely</b> No habitat is present within the project study area.
<i>Arctostaphylos pumila</i> Sandmat manzanita	-- / -- / 1B	Openings of closed-cone coniferous forests, maritime chaparral, cismontane woodland, coastal dunes, and coastal scrub on sandy soils at elevations of 3-205 meters. Evergreen shrub in the Ericaceae family; blooms February-May.	<b>Low</b> Marginal habitat is present within the project study area. The nearest CNDDDB occurrence is a historic occurrence from 1952, and is located adjacent to the project study area.
<i>Astragalus tener</i> var. <i>titi</i> Coastal dunes milk-vetch	FE / SE / 1B	Sandy soils in coastal bluff scrub, coastal dunes, coastal prairie (mesic); elevation 3-164 feet. Annual herb in the Fabaceae family; blooms March-May.	<b>Unlikely</b> No habitat is present within the project study area.
<i>Bryoria spiralifera</i> Twisted horsehair lichen	-- / -- / 1B.1	California North Coast coniferous forest at elevations of 0-30 meters. Often found on conifers, including <i>Picea sitchensis</i> , <i>Pinus contorta</i> var. <i>contorta</i> , <i>Pseudotsuga menziesii</i> , <i>Abies grandis</i> , and <i>Tsuga heterophylla</i> . Fruticose lichen in the Parmeliaceae family.	<b>Low</b> Suitable habitat is present in the project study area; however, the project study area is just outside of the elevation range of this species. The nearest CNDDDB occurrence is approximately 2.3 miles away.
<i>Castilleja ambigua</i> var. <i>insalutata</i> Pink johnny-nip	-- / -- / 1B	Coastal prairie and coastal scrub at elevations of 0-100 meters. Annual herb in the Orobanchaceae family; blooms May-August.	<b>Unlikely</b> No habitat is present within the project study area.
<i>Centromadia parryi</i> ssp. <i>congdonii</i> Congdon's tarplant	-- / -- / 1B	Valley and foothill grassland on alkaline soils at elevations of 0-230 meters. Annual herb in the Asteraceae family; blooms May-November.	<b>Unlikely</b> No habitat is present within the project study area.

Species	Status (Service/ Department/CNPS)	General Habitat	Potential Occurrence within Project Vicinity
<i>Chorizanthe pungens</i> var. <i>pungens</i> Monterey spineflower	FT / -- / 1B	Maritime chaparral, cismontane woodland, coastal dunes, coastal scrub, and valley and foothill grassland on sandy soils at elevations of 3-450 meters. Annual herb in the Polygonaceae family; blooms April-July.	<b>Unlikely</b> No habitat is present within the project study area.
<i>Clarkia jolonensis</i> Jolon clarkia	-- / -- / 1B	Cismontane woodland, chaparral, riparian woodland, and coastal scrub at elevations of 20-660 meters. Annual herb in the Onagraceae family; blooms April-June.	<b>Low</b> A historic CNDDDB occurrence from 1903 is located adjacent to the project study area. Additional occurrences, most historic, exist in the vicinity of the project area. The most modern occurrence in the vicinity of the project area is from 1963 and is approximately 3.3 miles away.
<i>Collinsia multicolor</i> San Francisco collinsia	-- / -- / 1B	Closed-cone coniferous forest and coastal scrub, sometimes on serpentinite soils, at elevations of 30-250 meters. Annual herb in the Plantaginaceae family; blooms March-May.	<b>Low</b> Habitat is present within the project study area. The nearest CNDDDB occurrence is a historic occurrence from 1903 and is located approximately 3 miles from the project study site.
<i>Cordylanthus rigidus</i> ssp. <i>littoralis</i> Seaside bird's-beak	-- / SE / 1B	Closed-cone coniferous forests, maritime chaparral, cismontane woodlands, coastal dunes, and coastal scrub on sandy soils, often on disturbed sites, at elevations of 0-425 meters. Annual hemiparasitic herb in the Orobanchaceae family; blooms April-October.	<b>Low</b> Habitat is present within the project study area. The nearest CNDDDB occurrence is a historic occurrence from 1940 and is approximately 3.2 miles from the project study site.
<i>Delphinium californicum</i> ssp. <i>interius</i> Hospital Canyon California larkspur	-- / -- / 1B	Openings in chaparral, coastal scrub, and mesic areas of cismontane woodland at elevations of 230-1095 meters. Perennial herb in the Ranunculaceae family; blooms April-June.	<b>Unlikely</b> No habitat is present within the project study area.

Species	Status (Service/ Department/CNPS)	General Habitat	Potential Occurrence within Project Vicinity
<i>Delphinium hutchinsoniae</i> Hutchinson's larkspur	-- / -- / 1B	Broadleaved upland forest, chaparral, coastal scrub, and coastal prairie at elevations of 0-427 meters. Perennial herb in the Ranunculaceae family; blooms March-June.	<b>Unlikely</b> No habitat is present within the project study area.
<i>Ericameria fasciculata</i> Eastwood's goldenbush	-- / -- / 1B	Openings in closed-cone coniferous forest, maritime chaparral, coastal dunes, and coastal scrub on sandy soils at elevations of 30-275 meters. Evergreen shrub in the Asteraceae family; blooms July-October.	<b>Low</b> Marginal habitat is present within the project study area. The nearest CNDDDB occurrence is a historic occurrence from 1913, and is located adjacent to the project study area
<i>Eriogonum nortonii</i> Pinnacles buckwheat	-- / -- / 1B	Chaparral and valley and foothill grassland on sandy soils, often on recent burns, at elevations of 300-975 meters. Annual herb in the Polygonaceae family; blooms May-September.	<b>Unlikely</b> No habitat is present within the project study area.
<i>Erysimum ammophilum</i> Sand-loving wallflower	-- / -- / 1B	Openings in maritime chaparral, coastal dunes, and coastal scrub on sandy soils at elevations of 0-60 meters. Perennial herb in the Brassicaceae family; blooms February-June.	<b>Unlikely</b> No habitat is present within the project study area.
<i>Erysimum menziesii</i> Menzies' wallflower	FE / SE / 1B	Coastal dunes at elevations of 0-35 meters. Perennial herb in the Brassicaceae family; blooms March-September.	<b>Unlikely</b> No habitat is present within the project study area.
<i>Fritillaria liliacea</i> Fragrant fritillary	-- / -- / 1B	Cismontane woodland, coastal prairie, coastal scrub, and valley and foothill grassland, often serpentinite, at elevations of 3-410 meters. Bulbiferous perennial herb in the Liliaceae family; blooms February-April.	<b>Low</b> Poor quality habitat is present within the project study area. A portion of the project study area is included in a historic CNDDDB occurrence from 1940. This is the only CNDDDB occurrence for the quads included in the search.
<i>Gilia tenuiflora</i> ssp. <i>arenaria</i> Monterey gilia	FE / ST / 1B	Openings in maritime chaparral, cismontane woodland, coastal dunes, and coastal scrub on sandy soils at elevations of 0-45 meters. Annual herb in the Polemoniaceae family; blooms April-June.	<b>Unlikely</b> No habitat is present within the project study area.

<b>Species</b>	<b>Status</b> (Service/ Department/CNPS)	<b>General Habitat</b>	<b>Potential Occurrence within Project Vicinity</b>
<i>Hesperocyparis goveniana</i> Gowen cypress	FT / -- / 1B	Closed-cone coniferous forest and maritime chaparral at elevations of 30-300 meters. Evergreen tree in the Cupressaceae family. Natively occurring only at Point Lobos near Gibson Creek and the Huckleberry Hill Nature Preserve near Highway 68.	<b>Low</b> The project study site is not located in the two known native stands.
<i>Hesperocyparis macrocarpa</i> Monterey cypress	-- / -- / 1B	Closed-cone coniferous forest at elevations of 10-30 meters. Evergreen tree in the Cupressaceae family. Natively occurring only at Cypress Point in Pebble Beach and Point Lobos State Park; widely planted and naturalized elsewhere.	<b>Low</b> The project study site is not located in the known native stands. The nearest CNDDDB occurrence is approximately 1.5 miles away from the project study area.
<i>Horkelia cuneata</i> var. <i>sericea</i> Kellogg's horkelia	-- / -- / 1B.1	Openings of closed-cone coniferous forests, maritime chaparral, coastal dunes, and coastal scrub on sandy or gravelly soils at elevations of 10-200 meters. Perennial herb in the Rosaceae family; blooms April-September.	<b>Low</b> Marginal habitat is present within the project study area. The nearest CNDDDB occurrence is a historic occurrence from 1896, and is located adjacent to the project study area
<i>Horkelia marinensis</i> <i>Point Reyes horkelia</i>	-- / -- / 1B	Coastal dunes, coastal prairie, and coastal scrub on sandy soils at elevations of 5-350 meters. Perennial herb in the Rosaceae family; blooms May-September.	<b>Unlikely</b> No habitat is present within the project study area.
<i>Lasthenia conjugens</i> Contra Costa goldfields	FE / -- / 1B	Mesic areas of valley and foothill grassland, alkaline playas, cismontane woodland, and vernal pools at elevations of 0-470 meters. Annual herb in the Asteraceae family; blooms March-June.	<b>Unlikely</b> No habitat is present within the project study area.
<i>Layia carnosa</i> Beach layia	FE / SE / 1B	Coastal dunes and coastal scrub on sandy soils at elevations of 0-60 meters. Annual herb in the Asteraceae family; blooms March-July.	<b>Unlikely</b> No habitat is present within the project study area.
<i>Lupinus tidestromii</i> Tidestrom's lupine	FE / SE / 1B	Coastal dunes at elevations of 0-100 meters. Perennial rhizomatous herb in the Fabaceae family; blooms April-June.	<b>Unlikely</b> No habitat is present within the project study area.
<i>Malacothamnus palmeri</i> var. <i>involutus</i> Carmel Valley bush-mallow	-- / -- / 1B	Chaparral, cismontane woodland, and coastal scrub at elevations of 30-1100 meters. Perennial deciduous shrub in the Malvaceae family; blooms May-October.	<b>Low</b> Poor quality habitat present within the project study area.
<i>Malacothamnus palmeri</i> var. <i>palmeri</i> Santa Lucia bush-mallow	-- / -- / 1B	Chaparral on rocky soils at elevations of 60-360 meters. Perennial deciduous shrub in the Malvaceae family; blooms May-July.	<b>Unlikely</b> No habitat is present within the project study area.

Species	Status (Service/ Department/CNPS)	General Habitat	Potential Occurrence within Project Vicinity
<i>Malacothrix saxatilis</i> var. <i>arachnoidea</i> Carmel Valley malacothrix	-- / -- / 1B	Chaparral and coastal scrub on rocky soils at elevations of 25-1036 meters. Perennial rhizomatous herb in the Asteraceae family; blooms June-December.	<b>Unlikely</b> No habitat is present within the project study area.
<i>Microseris paludosa</i> Marsh microseris	-- / -- / 1B	Closed-cone coniferous forest, cismontane woodland, coastal scrub, and valley and foothill grassland at elevations of 5-300 meters. Perennial herb in the Asteraceae family; blooms April-July.	<b>Low</b> Marginal habitat is present within the project study site. Two historic CNDDDB occurrences, one from 1901 and the other from 1970, are located within 0.8 miles of the project study area. The most modern occurrence within the immediate vicinity of the project area is from 2001 and is located approximately 2.9 miles from the project study area.
<i>Monardella sinuata</i> ssp. <i>nigrescens</i> Northern curly-leaved monardella	-- / -- / 1B	Chaparral, coastal dunes, coastal scrub, and lower montane coniferous forest (ponderosa pine sandhills) on sandy soils at elevations of 0-300 meters. Annual herb in the Lamiaceae family; blooms April-September.	<b>Unlikely</b> No habitat is present within the project study area.
<i>Monolopia gracilens</i> Woodland woollythreads	-- / -- / 1B	Openings of broadleaved upland forest, chaparral, cismontane woodland, North Coast coniferous forest, and valley and foothill grassland on serpentinite soils at elevations of 100-1200 meters. Annual herb in the Asteraceae family; blooms February-July.	<b>Unlikely</b> No habitat is present within the project study area.
<i>Pinus radiata</i> Monterey pine	-- / -- / 1B	Closed-cone coniferous forest and cismontane woodland at elevations of 25-185 meters. Evergreen tree in the Pinaceae family. Only three native stands in CA at Ano Nuevo, Cambria, and the Monterey Peninsula; introduced in many areas.	<b>Present</b> The project study area is located within one of the native stands.
<i>Piperia yadonii</i> Yadon's rein orchid	FE / -- / 1B	Sandy soils in coastal bluff scrub, closed-cone coniferous forest, and maritime chaparral at elevations of 10-510 meters. Annual herb in the Orchidaceae family; blooms February-August.	<b>Moderate</b> Habitat is present within the project study area but is degraded. The nearest CNDDDB occurrence is approximately 0.2 miles from the project study area.



Species	Status (Service/ Department/CNPS)	General Habitat	Potential Occurrence within Project Vicinity
<i>Plagiobothrys uncinatus</i> Hooked popcorn-flower	-- / -- / 1B	Chaparral, cismontane woodlands, and valley and foothill grasslands on sandy soils at elevations of 300-760 meters. Annual herb in the Boraginaceae family; blooms April-May.	<b>Unlikely</b> The project study site is outside of the elevation range of this species.
<i>Potentilla hickmanii</i> Hickman's cinquefoil	FE / SE / 1B	Coastal bluff scrub, closed-cone coniferous forests, vernal mesic meadows and seeps, and freshwater marshes and swamps at elevations of 10-149 meters. Perennial herb in the Rosaceae family; blooms April-August.	<b>Low</b> Poor quality habitat located in the project study area. The nearest CNDDDB occurrence is a historic occurrence from 1900, located approximately 1.6 miles from the project study site. The nearest modern occurrence is from 2005 and is approximately 2.4 miles away from the project study area.
<i>Ramalina thrausta</i> Angel's hair lichen	-- / -- / 2B.1	North coast coniferous forest on dead twigs and other lichens. Epiphytic fructose lichen in the Ramalinaceae family. In northern CA it is usually found on dead twigs, and has been found on <i>Alnus rubra</i> , <i>Calocedrus decurrens</i> , <i>Pseudotsuga menziesii</i> , <i>Quercus garryana</i> , and <i>Rubus spectabilis</i> . In Sonoma County it grows on and among dangling mats of <i>R. menziesii</i> and <i>Usnea</i> spp.	<b>Low</b> The nearest CNDDDB occurrence is approximately 1.4 miles from the project study area and is the only known occurrence of this species in the quads included in the CNDDDB search.
<i>Rosa pinetorum</i> Pine rose	-- / -- / 1B	Closed-cone coniferous forest at elevations of 2-300 meters. Perennial shrub in the Rosaceae family; blooms May-July. Possible hybrid of <i>R. spithamea</i> , <i>R. gymnocarpa</i> , or others; further study needed.	<b>Moderate</b> Habitat is present within the project study area but is degraded. The nearest CNDDDB occurrence is approximately 1.2 miles from the project study site.
<i>Sidalcea malachroides</i> Maple-leaved checkerbloom	-- / -- / List 4	Broadleaved upland forest, coastal prairie, coastal scrub, North Coast coniferous forest, and riparian woodlands, often in disturbed areas, at elevations of 2-730 meters. Perennial herb in the Malvaceae family; blooms March-August.	<b>Low</b> Suitable habitat is present within the project study area. The nearest CNDDDB occurrence is a historic occurrence from 1881, located approximately 3 miles from the project study site.

Species	Status (Service/ Department/CNPS)	General Habitat	Potential Occurrence within Project Vicinity
<i>Stebbinsoseris decipiens</i> Santa Cruz microseris	-- / -- / 1B	Broadleaved upland forest, closed-cone coniferous forest, chaparral, coastal prairie, coastal scrub, and openings in valley and foothill grassland, sometimes on serpentinite, at elevations of 10-500 meters. Annual herb in the Asteraceae family; blooms April-May.	<b>Low</b> The nearest CNDDDB occurrence is approximately 5.2 miles from the project study site.
<i>Tortula californica</i> California screw moss	-- / -- / 1B	Valley and foothill grassland and chenopod scrub on sandy soils at elevations of 10-1460 meters. Moss in the Pottiaceae family.	<b>Unlikely</b> No habitat is present within the project study area.
<i>Trifolium buckwestiorum</i> Santa Cruz clover	-- / -- / 1B	Gravelly margins of broadleaved upland forest, cismontane woodland, and coastal prairie at elevations of 105-610 meters. Annual herb in the Fabaceae family; blooms April-October.	<b>Unlikely</b> No habitat is present within the project study area.
<i>Trifolium hydrophilum</i> Saline clover	-- / -- / 1B	Marshes and swamps, mesic and alkaline valley and foothill grassland, and vernal pools at elevations of 0-300 meters. Annual herb in the Fabaceae family; blooms April-June.	<b>Unlikely</b> No habitat is present within the project study area.
<i>Trifolium polyodon</i> Pacific Grove clover	-- / SR / 1B	Mesic areas of closed-cone coniferous forest, coastal prairie, meadows and seeps, and valley and foothill grassland at elevations of 5-120 meters. Annual herb in the Fabaceae family; blooms April-July.	<b>Low</b> Poor quality habitat is present within the project study area. The nearest CNDDDB occurrence is approximately 1.7 miles from the project study area.
<i>Trifolium trichocalyx</i> Monterey clover	FE / SE / 1B	Sandy openings and burned areas of closed-cone coniferous forest at elevations of 30-240 meters. Annual herb in the Fabaceae family; blooms April-June.	<b>Low</b> Poor quality habitat is present within the project study area. The nearest CNDDDB occurrence is approximately 1.1 miles from the project study area.

#### STATUS DEFINITIONS

##### Federal

- FE = listed as Endangered under the federal Endangered Species Act  
 FT = listed as Threatened under the federal Endangered Species Act  
 FC = Candidate for listing under the federal Endangered Species Act  
 -- = no listing

**State**

SE = listed as Endangered under the California Endangered Species Act

ST = listed as Threatened under the California Endangered Species Act

SR = listed as Rare under the California Endangered Species Act

SC = Candidate for listing under the California Endangered Species Act

CSC = California Department of Fish and Wildlife Species of Concern

CFP = California Fully Protected Animal

CNBBD = This designation is being assigned to animal species with no other status designation defined in this table. These animal species are included in the Department's CNDDDB "Special Animals" list (2010), which includes all taxa the CNDDDB is interested in tracking, regardless of their legal or protection status. This list is also referred to as the list of "species at risk" or "special-status species." The Department considers the taxa on this list to be those of the greatest conservation need.

-- = no listing

**California Native Plant Society**

1B = List 1B species; rare, threatened or endangered in California and elsewhere

List 4 = Limited distribution (CNPS Watch List)

-- = no listing

**POTENTIAL TO OCCUR**

Present = known occurrence of species within the site; presence of suitable habitat conditions; or observed during field surveys

High = known occurrence of species in the vicinity from the CNDDDB or other documentation; presence of suitable habitat conditions

Moderate = known occurrence of species in the vicinity from the CNDDDB or other documentation; presence of marginal habitat conditions within the site

Low = species known to occur in the vicinity from the CNDDDB or other documentation; lack of suitable habitat or poor quality

Unlikely = species not known to occur in the vicinity from the CNDDDB or other documentation, no suitable habitat is present within the site

Not Present = species was not observed during surveys